



Safety in the use of narrow band saws

Woodworking Sheet No 31

Introduction

This information sheet is one of a series produced by HSE's Woodworking National Interest Group. Its purpose is to give practical guidance on safe working practices when using narrow band-saws (blades ≤ 50 mm in width) for curved and irregular work, circular work, bevel, tenon and wedge cutting as well as cutting with and without a fence.

Legal requirements covering the use of these machines are contained in the Provision and Use of Work Equipment Regulations 1998.

Accident history

In a study of 1000 accidents at woodworking machines, 4% occurred on narrow band sawing machines. Most resulted from contact with the moving blade while presenting material to the blade or removing it from the table. Accidents also occurred while setting, cleaning, adjusting and maintaining the machine while the blade was still in motion.

Guarding

The pulleys and the blade, except the part which runs downwards between the top pulley and the machine table, should be enclosed by substantial guards. On machines bearing a 'CE mark', in accordance with the Supply of Machinery (Safety) Regulations 1992 (as amended), these guards should be interlocked with the machine drive.

An adjustable guard should be provided to fully enclose that portion of the blade between the table and the top pulley enclosure. This guard should be attached to and moved with the top blade guide. It should be capable of being easily adjusted to suit the height of the workpiece and firmly secured in position.

The part of the blade between the underside of the table and the lower guide should be guarded at all angles of table tilt.

Machine setting

For a narrow band saw to cut accurately and efficiently:

- the blade type and width should be suitable for the material being cut;
- the blade teeth sharp and properly set;

- the blade correctly tensioned and tracked; and
- the maximum thickness of blade suitable for the pulley wheel diameter.

Tensioning

A saw keeps its condition longer if the tension on the blade is relaxed after use, eg at the end of a working period. A notice should be placed on the machine to indicate this and to remind the next user to adjust the tension before starting the saw.

Tracking

Tracking helps the blade run in the correct position on the band-saw pulleys. This is achieved by tilting the top pulley.

When tracking, the thrust wheels and guides should be clear of the blade to allow it to move freely. With the machine isolated, the top pulley should be rotated by hand and tilted until the blade runs in the correct position.

With the guides and thrust wheel correctly positioned and the guards in the closed position, run the machine under power. If the blade does not run correctly when under power, the manual tracking should be repeated. After tracking, the tension of the blade should be rechecked.

Saw blade guides and thrust wheels

The saw blade guides, which can be fixed pads, pegs or rotating rollers, should support the blade behind the gullets. They should not grip the blade but should support it during cutting.

The thrust wheels give support to the blade when cutting. They should be positioned in line and just clear of the back of the blade when the blade is idling after being tensioned and tracked. Lack of clearance will cause grooving of the thrust wheels and lead to blade failure.

Machine operation

The saw guides and attached adjustable guard should be adjusted as close to the workpiece as possible before machining and kept in place during machining.

Power feed

Use a demountable power feed wherever possible, eg when cutting with a fence. This will remove the need for

close approach to the blade by the operator and increase the output of the machine. By maintaining a constant feed rate, the device helps to prolong the working periods between blade sharpening (see Figure 1).

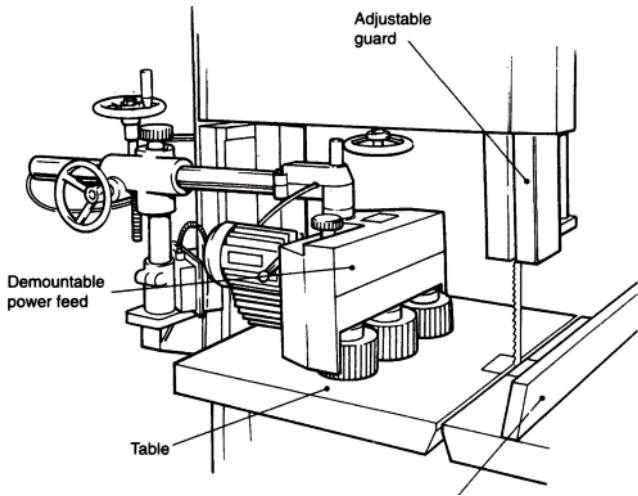

Figure 1 Narrow band saw with demountable power feed

Cutting with a fence

Always use a fence for straight cutting to prevent the workpiece rocking or sliding (see Figure 2). For shallow work, use a low position fence to allow the blade guides and guard to be adjusted down to the workpiece and also to permit safe removal of material from the blade using a push stick.

When hand feeding against a fence use a wooden guide block to exert an even pressure on the workpiece. Use a push stick for feeding close to the blade (see Figure 2).

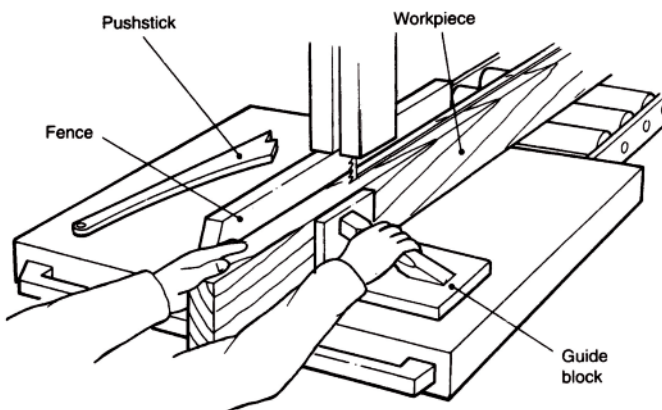

Figure 2 Straight cutting

Cutting without a fence

Where it is not practicable to use a fence, the workpiece should be fed forward evenly (without exerting excess pressure) and held firmly on the table to ensure effective control during cutting. The hands should be kept in a

safe position (see Figure 3) by keeping them as far away from the blade as possible. When hands are unavoidably near to the blade they should be placed on either side of the blade, not in line with it (see Figure 4).

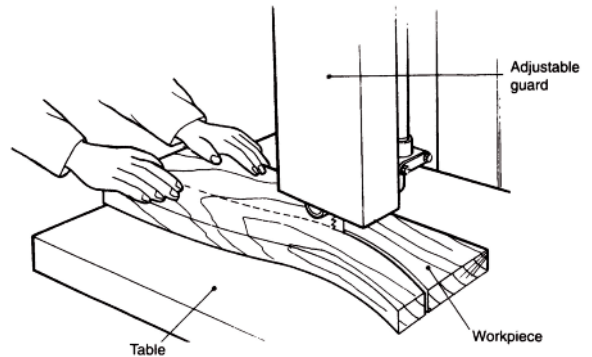

Figure 3 Handling shaped work on a narrow band saw

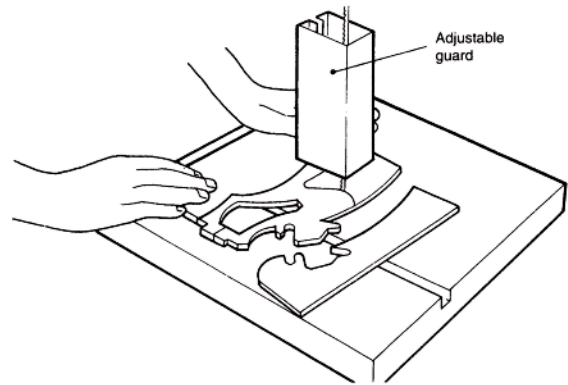

Figure 4 Freehand cutting

Curved or irregular work

A variety of curved or irregular shapes can be produced with or without a template (see Figure 4).

For repetitive work, a guide fixed in front of the blade used with a template improves safety as well as the speed of operation (see Figure 5).

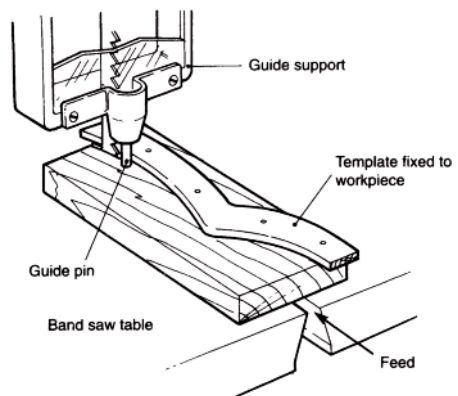

Figure 5 Cutting irregular shapes on a narrow band sawing machine using a template and guide

Bevel cutting

Bevel cutting is usually done by tilting the table, which means that additional workpiece support, such as a fence, is required to prevent the workpiece falling from the table. On machines with a fixed table or tiltable fence a jig is necessary to provide support for the workpiece. Push sticks should be used at the end of the cut (see Figure 6).

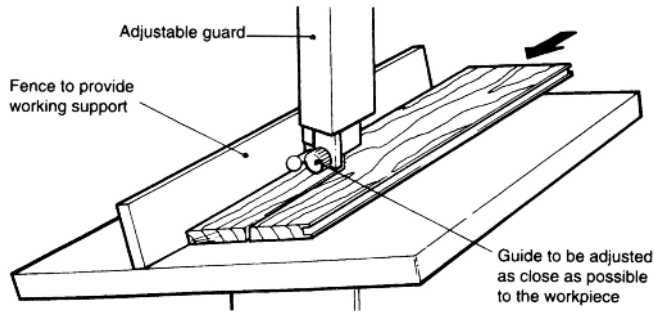

Figure 6 Bevel cutting using a tilting table

Diagonal cuts on square stock can be achieved by feeding the workpiece through a trough type of jig fixed to the table (see Figure 7).

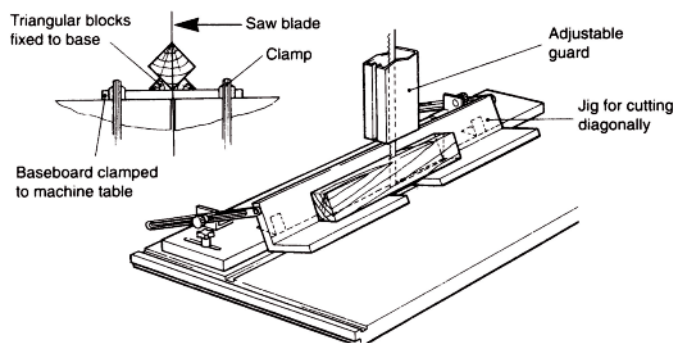

Figure 7 Diagonal cutting

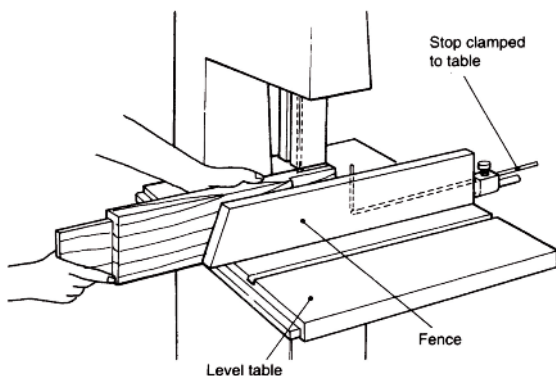

Figure 8 Cutting tenons on a narrow band sawing machine using a fence and back stop

Cutting tenons

Simple tenons can be cut (see Figure 8). For complex tenons or repetitive work, jigs provide the safest system of work.

Wedge cutting

Small wedges can be cut safely using the holder shown in Figure 9.

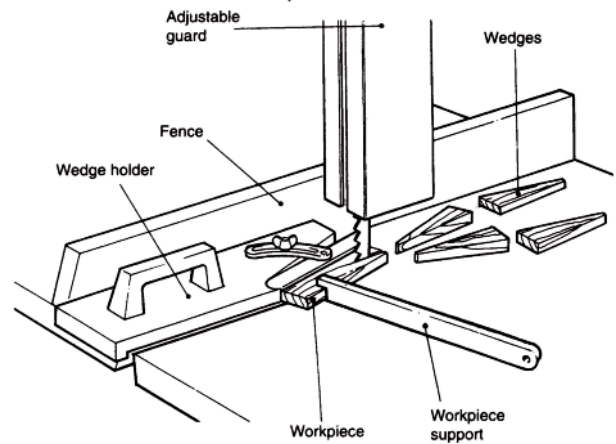

Figure 9 Wedge cutting

Circular work

A jig for cutting circular discs is shown in Figure 10.

The workpiece is placed centrally on the pivot, with one edge touching the saw blade, and rotated to produce a circular disc. The cut should start on the end grain and the workpiece should be fed slowly with even pressure.

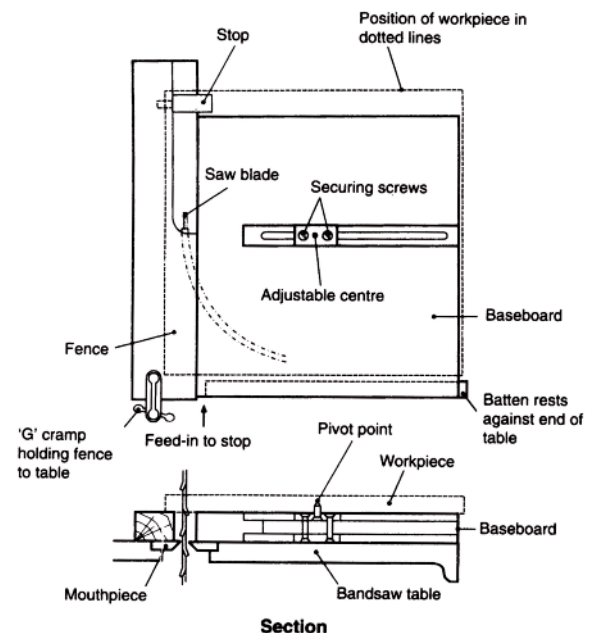

Figure 10 Regular cutting of circular saws

Cross-cutting or ripping round stock

The workpiece will need to be secured to prevent rotation, caused by the cutting pressure. It should be held in a suitable jig or holder. The blade should be suitable for cross-cutting.

Workpiece support

The table should support the whole workpiece. When a workpiece overhangs the table it should be supported using extension tables or roller trestles at both infeed and outfeed. Tipping of the workpiece is a common cause of accidents.

Safety devices

Guide blocks should be used when hand feeding against a fence and push sticks used for feeding timber close to the blade and removing cut pieces from between the saw and fence.

Cleaning and maintenance

Never clean the blade or pulley with a hand-held brush or scraper while the blade is in motion. Careful adjustment and regular maintenance of blade and pulley cleaning equipment will ensure resin residues do not build up.

A routine maintenance schedule should be drawn up to include, for example blade condition, pulley bearing wear, pulley wear, correct operation of guides and thrust wheels, blade tensioning device, blade and pulley cleaning equipment, guards and safety devices.

Tool selection

The correct width of saw blade should be selected by measuring the smallest radius of any curve to be cut. Machinists should choose the widest blade which will cut this curve without bending. Excessive blade twisting may cause blade breakage.

The tooth pitch should be chosen to suit the material thickness, ie the pitch should not exceed the depth of material being cut, and the tooth form should suit the material being sawn, ie standard tooth used for natural timber. Follow manufacturer's recommendations.

Tool handling

Care should be taken to avoid damaging the saw blade. When not in use, narrow band-saw blades should be coiled into thirds and secured. Store blades in a safe dry place and before use check for damaged teeth and cracks. Transport blades in jigs.

Training

Operators of band saws should be trained in:

- principles of machine operation, correct use and adjustment of the tilting table, fence, jigs, holders and templates;

- selection of the correct blade for the operation, the set of the teeth, tensioning and tracking of the blade;
- safe handling of the workpiece when cutting and position of the hands relative to the blade;
- correct adjustment of the top guide and guard and blade guard below the table.

Reading list and references

1 *Safe use of woodworking machinery. Provision and use of Work Equipment Regulations 1998 as applied to woodworking machinery. Approved Code of Practice and guidance* L114 HSE Books 1998
ISBN 0 7176 1630 4

2 *Safe use of work equipment. Provision and Use of Work Equipment Regulations 1998. Approved Code of Practice and guidance* L22 HSE Books 1998
ISBN 0 7176 1626 6

3 BS EN 1807: 1999 *Safety of woodworking machines - Band sawing machines*

4 Set of six woodworking posters HSE Books 1999
ISBN 0 7176 2433 1

Further information

HSE priced and free publications can be viewed online or ordered from www.hse.gov.uk or contact HSE Books, PO Box 1999, Sudbury, Suffolk CO10 2WA
Tel: 01787 881165 Fax: 01787 313995. HSE priced publications are also available from bookshops.

For information about health and safety ring HSE's Infoline Tel: 0845 345 0055 Fax: 0845 408 9566
Textphone: 0845 408 9577
e-mail: hse.infoline@natbrit.com or write to HSE Information Services, Caerphilly Business Park, Caerphilly CF83 3GG.

British Standards can be obtained in PDF or hard copy formats from the BSI online shop: www.bsigroup.com/Shop or by contacting BSI Customer Services for hard copies only Tel: 020 8996 9001 e-mail: cservices@bsigroup.com.

This leaflet contains notes on good practice which are not compulsory but which you may find helpful in considering what you need to do.

© *Crown copyright* This publication may be freely reproduced, except for advertising, endorsement or commercial purposes. First published 12/94. Please acknowledge the source as HSE.