



Woodworking machinery at its best!

VARIABLE SPEED WOODTURNING LATHE

MODEL: W824



Charnwood, Cedar Court, Walker Road,
Hilltop Industrial Estate, Bardon Hill, Leicestershire, LE67 1TU

Tel. 01530 516 926 Fax. 01530 516 929
email: sales@charnwood.net website: www.charnwood.net

GENERAL SAFETY RULES

WARNING: Do not attempt to operate the machine until you have read thoroughly and understood completely all instructions, rules, etc. contained in this manual. Failure to comply may result in accidents involving fire, electric shock, or serious personal injury. Keep this owner's manual and review frequently for continuous safe operation.

1. Know your machine. For your own safety, read the owner's manual carefully. Learn its application and limitations, as well as specific potential hazards pertinent to this machine.

2. Make sure all tools are properly earthed.

3. Keep guards in place and in working order. If a guard must be removed for maintenance or cleaning, make sure it is properly replaced before using the machine again.

4. Remove adjusting keys and spanners. Form a habit of checking to see that the keys and adjusting spanners are removed from the machine before switched it on.

5. Keep your work area clean. Cluttered areas and workbenches increase the chance of an accident.

6. Do not use in dangerous environments. Do not use power tools in damp or wet locations, or expose them to rain. Keep work areas well illuminated.

7. Keep children away. All visitors should be kept a safe distance from the work area.

8. Make workshop childproof. Use padlocks, master switches and remove starter keys.

9. Do not force the machine. It will do the job better and be safer at the rate for which it is designed.

10. Use the right tools. Do not force the machine or attachments to do a job for which they are not designed. Contact the manufacturer or distributor if there is any question about the machine's suitability for a particular job.

11. Wear proper apparel. Avoid loose clothing, gloves, ties, rings, bracelets, and jewellery which could get caught in moving parts. Non-slip footwear is recommended. Wear protective hair covering to contain long hair.

12. Always use safety glasses. Normal spectacles only have impact resistant lenses. They are not safety glasses.

13. Do not over-reach. Keep proper footing and balance at all times.

14. Maintain machine in good condition. Keep machine clean for best and safest performance. Follow instructions for lubrication and changing accessories.

15. Disconnect the machine from power source before servicing and when changing the drive belt.

16. To avoid accidental starting, make sure the switch is in the OFF position before plugging in the mains cable.

17. Never leave the machine running unattended. Turn the power off. Do not leave the machine until it comes to a complete stop.
18. Do not use any power tools while under the effects of drugs, alcohol or medication.
19. Always wear a face or dust mask if operation creates a lot of dust and/or chips. Always operate the tool in a well ventilated area and provide for proper dust removal. Use a suitable dust extractor.

ADDITIONAL RULES FOR LATHES

Never attempt to adjust any part of the workpiece whilst the lathe is still in motion. Wait until the workpiece has come to a complete stop.

1. Ensure that chuck keys, tommy bars and similar items are removed before the lathe is started.
2. Always stand to one side when you start the lathe so that if anything does fly off e.g. a loose piece of bark, you will be out of the line-of-fire.
3. When mounting a new piece of timber, rotate the wood through 360° by hand to ensure that it will not hit the tool rest or the bed of the lathe and then start the lathe at its slowest speed. When you are certain that that the work is secure and not too out of balance set the lathe to the normal turning speed.
4. Always check the rotation speed before switching the lathe on to avoid the risk of starting it whilst it is set to run at too high a speed.
5. The speed of the lathe must be adjusted to suit the size, balance, length and condition of the timber being turned. The greater the diameter of the work, the slower the rotation speed needs to be. If the piece you are turning is out of balance, then you must start turning at a low speed, until it is balanced.
6. The tool must rest firmly on the tool rest before it is brought into contact with the rotating wood and must never be lifted off the tool rest as long as it is in contact with the timber.
7. Before sanding, polishing or doing anything else that brings your fingers close to the work, remove the tool rest. Getting your fingers trapped between the tool rest and the work will at least be very painful and may cause serious injury.
8. Never wrap the sandpaper or polishing cloth round the work. If it tightens up it will pull your fingers into contact with the timber and may lead to serious injury.

Important



Risk of Injury!
Never reach into
Moving parts



Wear Eye
Protection



Wear Ear
Protection

Introduction

In order to get the most out of your lathe, please read through this manual and safety instructions before use.

Please keep the manual in case you need it in the future

Technical Data

N.B. The distance between centres will vary and be dependent on the type of centres or accessories used. Maximum distance is 450mm (18").

Distance between centres	360mm (14")
Distance over bed	300mm (12")
Motor DC (Carbon Brush)	550w (3/4hp) 240Vdc
Speed ranges (approx.)	500 - 2000rpm 1000 - 4000rpm
Spindle thread size	1" x 8tpi
Spindle tapers	2MT
Indexing Positions	24 (every 15 degrees)
Dimensions (WxDxH)	980mm x 310mm x 440mm
Weight	32kg
Rating	Hobby
Warranty	1 Year

Main Components

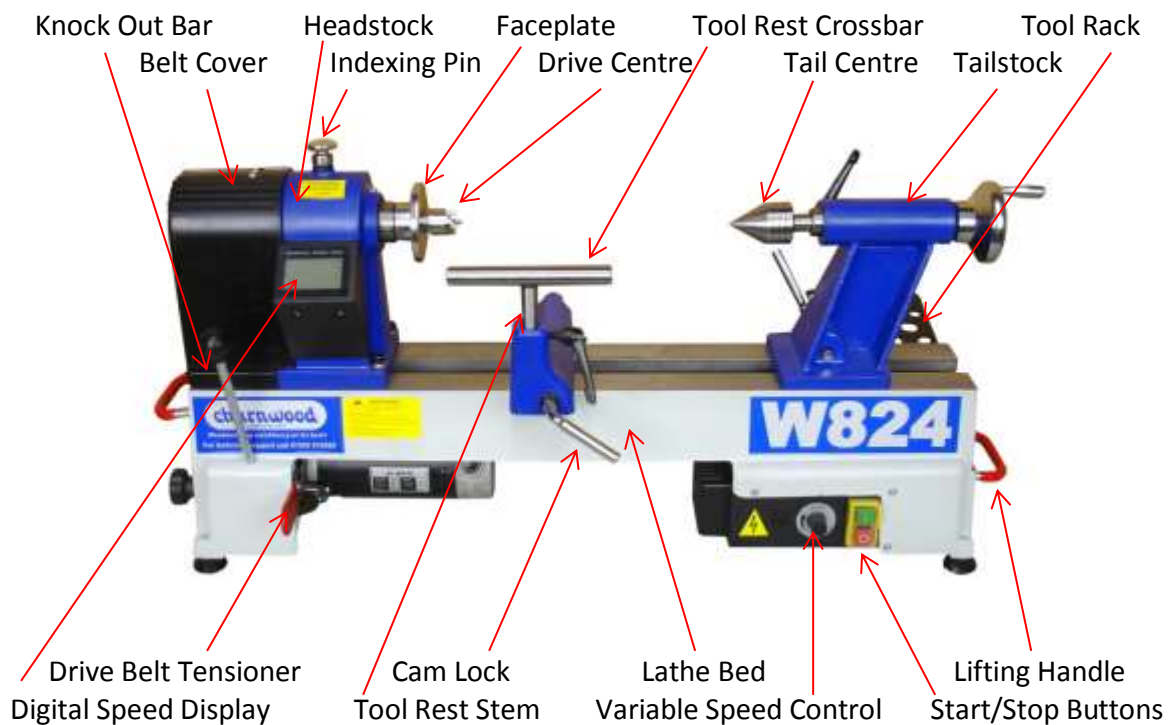

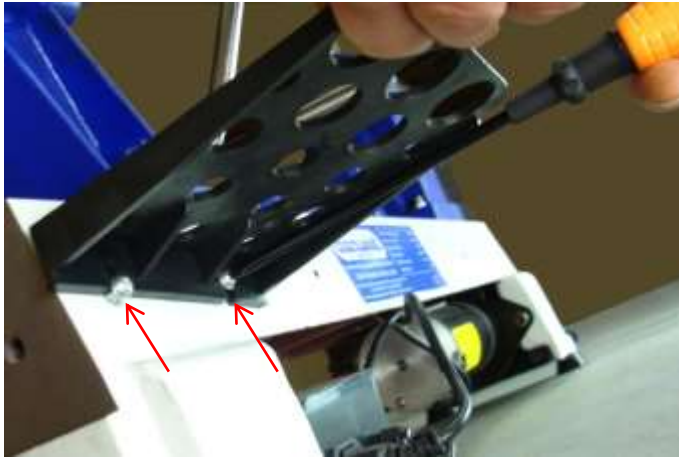

Using a cross-headed screwdriver, loosen the two screws in the rear of the lathe bed and attach the tool tray, ensuring the washers are positioned next to the screw head. Re-tighten the screws.



Attach the two cable tidy brackets with the four M5 x 12mm screws and washers provided.



Connect the Power Cord to the socket in the rear of the Speed Control Box.

**PLEASE NOTE:
THE POWER CORD MUST
NEVER BE CONNECTED
DIRECTLY TO THE MOTOR
CABLE. THE MOTOR IS A
DIRECT CURRENT TYPE AND
WOULD BE PERMANENTLY
DAMAGED.**



Using a flat bladed screwdriver, attach the handle to the tailstock hand wheel.

Adjusting the Spindle Speed

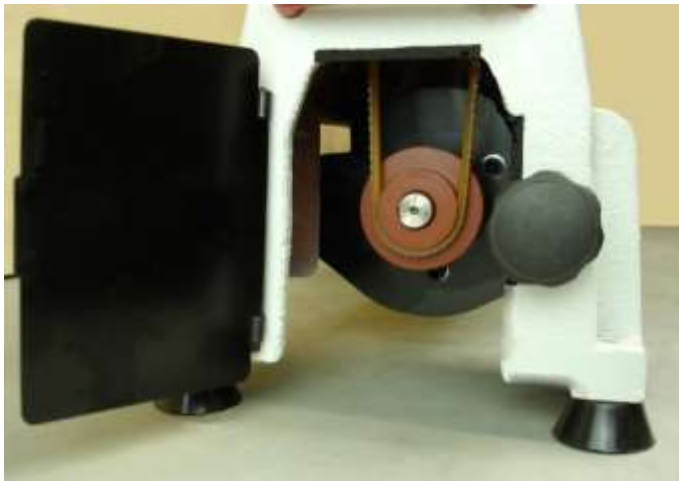

The lathe has electronic speed control. There are two ranges of speeds which are obtained by changing the position of the drive belt.

To adjust the drive belt position:

1) Open the bottom pulley access door.



2) Open the upper belt cover which is hinged at the bottom.

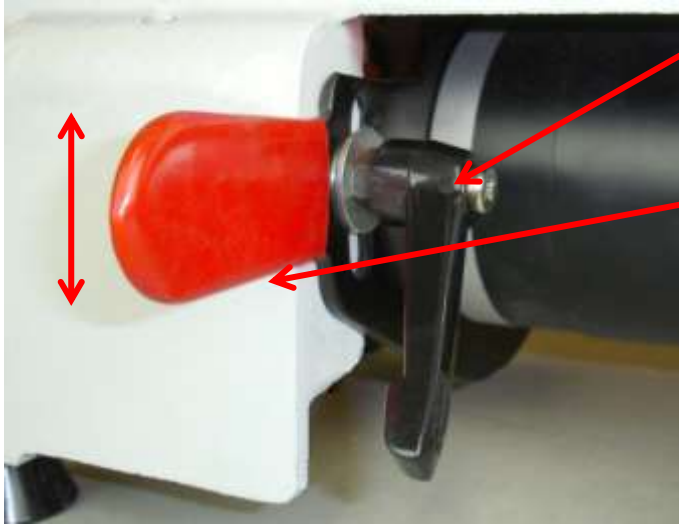

3) Loosen the belt tension lever locking handle.

4) Lift the belt tension lever and tighten into the raised position.

5) Move the slack belt to the alternate set of pulleys. Release the locking lever, apply light pressure to tension the belt and then re-tighten the locking handle.

6) Close the belt cover and the pulley door.

After switching on the lathe, adjust the speed using the variable speed control knob.

The **approximate** speed ranges are:

Left Hand Pulleys;
500rpm to 2000rpm

Right Hand Pulleys;
1000rpm to 4000rpm

The actual spindle speed will be displayed on the LCD screen.



Recommended Turning Speeds

Workpiece Diameter mm	Roughing Cuts RPM	General Cutting RPM	Finishing Cuts RPM
Under 50	1500	3200	3200
50-100	750	1600	2500
100-150	500	1000	1700
150-200	500	800	1250
200-250	500	650	1000
250-300	500	530	850

Using The Lathe



To slide the tailstock along the bed, pull up the silver tailstock locking lever.

When it is positioned where required, clamp it firmly in place by pressing the lever down firmly.

Fine adjustment of the tail centre is made by unlocking the winding handle locking lever (by half a turn only)

Now turn the winding handle to enable the tail centre to be advanced or retracted. It has a travel of 40mm.



The tool rest can be moved along the bed of the lathe.

To release the tool rest pull up the silver tool rest locking lever.

The tool rest can now freely slide along the bed, when it is positioned where required, clamp it firmly in place by pressing the lever down firmly.

The height of the tool rest can also be adjusted, using the black locking lever.

This type of lever can be rotated to a more convenient position, without moving the thread, by pulling the lever away from the thread to disengage the ratchet teeth and then rotating it.

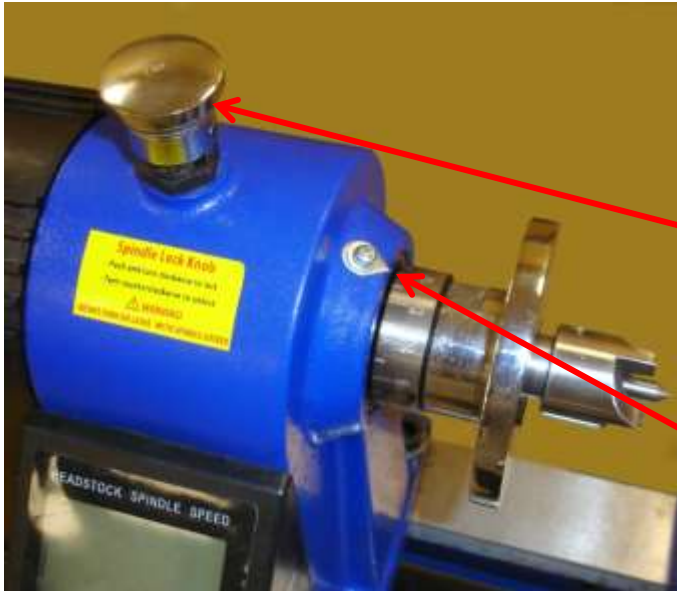

The lathe is fitted with an indexing system which allows the spindle to be locked in 24 positions (15 degree intervals)

The indexing facility is useful for fluted columns, clock faces and accurate hole placements.

To lock or unlock the spindle:
Lift and Rotate the locking knob.
Ensure that the vertical pin is engaged in the shallow hole and the spindle is free to rotate before starting the lathe.
Failure to do so could result in damage to the indexing mechanism.

To set a position:
Turn the faceplate and line up the desired position, then lift and rotate the locking knob ensuring the pin is in the deeper hole. The spindle is now locked in place.

Routine Maintenance

Replacing the Drive Belt

Eventually, the drive belt will become worn and require replacement.

To replace the belt, open the access door and top pulley cover. Release the tension as when changing the speed range and remove the old belt. Replace by feeding the new belt through the opening in the lathe bed and over the bottom pulley, then over the corresponding upper pulley. Apply tension and tighten the locking handle. Ensure that the V- grooves are on the inside of the belt and engaged with the grooves on the pulleys.

Replacing the Motor Brushes



The carbon brushes should be regularly inspected and will need changing after approximately 500 hours use, or when the block has worn down to a length of 7mm.

Unscrew the two black plastic screws found on either side of the motor.
Withdraw the worn brush and spring, then replace it with a new one.



Always replace both brushes at the same time.

CHARNWOOD W824 LATHE TROUBLESHOOTING GUIDE

Fault	Possible Cause	Remedy
Machine will not start	Power supply not connected Fuse in plug blown Break in power supply cable Loose terminal on switch Switch failed	Check plug connections in rear of control unit Replace fuse Visually check cable - replace if necessary Remove switch and check connections Replace switch
Machine will not start, Speed Display Lit	Indexing Pin Engaged Fuse in Control Panel blown Speed controller failed Carbon brushes worn	Disengage Indexing Pin Replace fuse Replace speed controller Replace carbon brushes
Machine starts only when green button held	Switch has failed	Replace Switch
Machine starts to turn but slow speed only	Failed variable speed circuit	Check connection to speed dial
Spindle stalls but motor still running	Loose drive belt	Increase belt tension
Motor is running but spindle not turning	Broken drive belt	Replace drive belt
Motor is overheating Too much load on motor	Too much load on motor Airflow around motor restricted	Reduce load - make shallower cuts Keep motor clear of shavings
Spindle rotation slows during cut	Excessive depth of cut Chisels are dull Worn carbon brushes Loose drive belt	Make shallower cuts Sharpen chisels Replace brushes Increase belt tension

Optional Accessories

Our full range of accessories for the wood turner can be viewed on our website at www.charnwood.net



Viper2 Geared Scroll Chuck, 70mm Diameter.

A compact scroll chuck, with the jaws adjusted by a geared mechanism for simple one handed operation. Self centring, high precision design.



DC16MT2 Drill Chuck

16mm Chuck Capacity with No.2 Morse taper (MT2) fitting.

Supplied with chuck key.



ML28 Flexible Light with Magnetic Base

28 LED bulbs, mains powered, the magnetic base light is ideal for locating the light wherever it is needed.



BS10 Deluxe Bowl Sander

The four foam backed, velcro faced sanding pads are a push fit into the head. The soft foam backing allows the pad to change shape and take the form of the piece being sanded, with only a light press.



PENK2MT Pen Turning Kit

This complete Pen turning kit contains all the tools you need to start pen turning including 5 different coloured 7mm diameter pens.

Declaration of Conformity for CE Marking

Charnwood Declare that Woodworking Lathe, Model W824

Conforms with the following Directives: Machinery Directive 2006/42/EC
EMC Directive 2014/30/EU

And further conforms to the machinery example for which the EC type examination Certificate No. AM 50292976 and AE 50355026 have been issued by TUV Rheinland LGA Products GmbH, Tillystrasse 2, 90431, Nurnberg, Germany.

I hereby declare that equipment named above has been tested and found to comply with the relevant sections of the above referenced specifications. The machinery complies with all essential requirements of the directive.

Signed: Richard Cook

Dated: 01/09/2016

Location: Leicestershire

Richard Cook
Director



Please dispose of packaging for the product in a responsible manner. It is suitable for recycling. Help to protect the environment, take the packaging to the local amenity tip and place into the appropriate recycling bin.



Only for EU countries
Do not dispose of electric tools together with household waste material!

In observance of European Directive 2002/96/EC on waste electrical and electronic equipment (WEEE) and its implementation in accordance with national law, electric tools that have reached the end of their life must be collected separately and returned to an environmentally compatible recycling facility.



Your local refuse amenity will have a separate collection area for WEEE goods

Charnwood W824 Parts List

Part No	Description	Part No	Description
001	Washer M4	002	Dome Head Screw M4 x 8mm
003	Hex Socket Screw M6 x 12mm	004	Hand Wheel
005	Dome Head Screw M6 x 24	006	Dome Head Screw M4 x 6mm
007	Hinge	008	Hex Nut M6
009	Side Protection Guard	010	Lock Piece
011	Cam Follower Tailstock	012	Main Shaft Sleeve
013	Bearing 80105	014	Retaining Ring 47mm
015	Shaft	016	Cap
017	Screw	018	Bush
019	Spring	020	Index Pin
021	Hex Socket Screw M8 x 30mm	022	Spring Washer
023	Washer M8	024	Nut M10
025	Indicator	026	Hex Head Screw M6 x 12mm
028A	Tool Post 5/8" Shank	028B	Cross Bar 6"
029	Retaining Ring 10mm	030	Tool Rest Cam Follower
031	Bolt	032	Spring
033	Handle	034	Lock Bolt
035	Tool Rest Base	036	Bush
037	Lock Handle for Tool Rest Base	038	Headstock Drive Centre MT2
039	Face Plate 3" diameter	040	Gear
041	Round Plate	042	Headstock Spindle
045	Nut M3	046	Connecting Plate
047	Washer	048	Dome Head Screw M3 x 12mm
049	Label	050	Dome Head Screw M4 x 12mm
051	Handling Handle	052	Clip
053	Front Protection Guard	054	Display Plate
055	Tapping Screw	057	Pin Hinge
058	Mounting Plate	059	Ball
060	Knock-out Rod	061	Hinge
062	Door Latch	063	Drive Belt
064	Connecting Rod	065	Spring
066	Washer	067	Main Body
068	Motor Pulley	069	Hex Socket Screw M6 x 16mm
070	Spring Washer	071	Washer M6
072	Motor Plate with Notch	073	Tapping Screw
074	Motor DC, 550w, 240v	075	Switch KJD20-2
078	Power Cable	079	Speed Control Unit
086	Lock Nut	087	Nut M10
088	Rubber Foot	089	Support
090	Dome Head Screw M5 x 12mm	091	Washer M5
092	Screw	093	Bush
094	Quill Adjusting Wheel	095	Eccentric Axis
096	Cam Follower Tailstock	097	Retaining Ring M10
098	Tailstock	099	Tailstock Quill
100	Dome Head Screw M5 x 12mm	101	Tailstock Axis
102	Tool Rack	103	Tailstock Revolving Centre MT2
106	Bed	107	Nut M10
108	Hex Socket Screw M8 x 16mm	109	Dome Head Screw M4 x 20mm
110	Knock out Bar	BRUSH	Carbon Brush (x2)

Charnwood W824 Parts Drawing

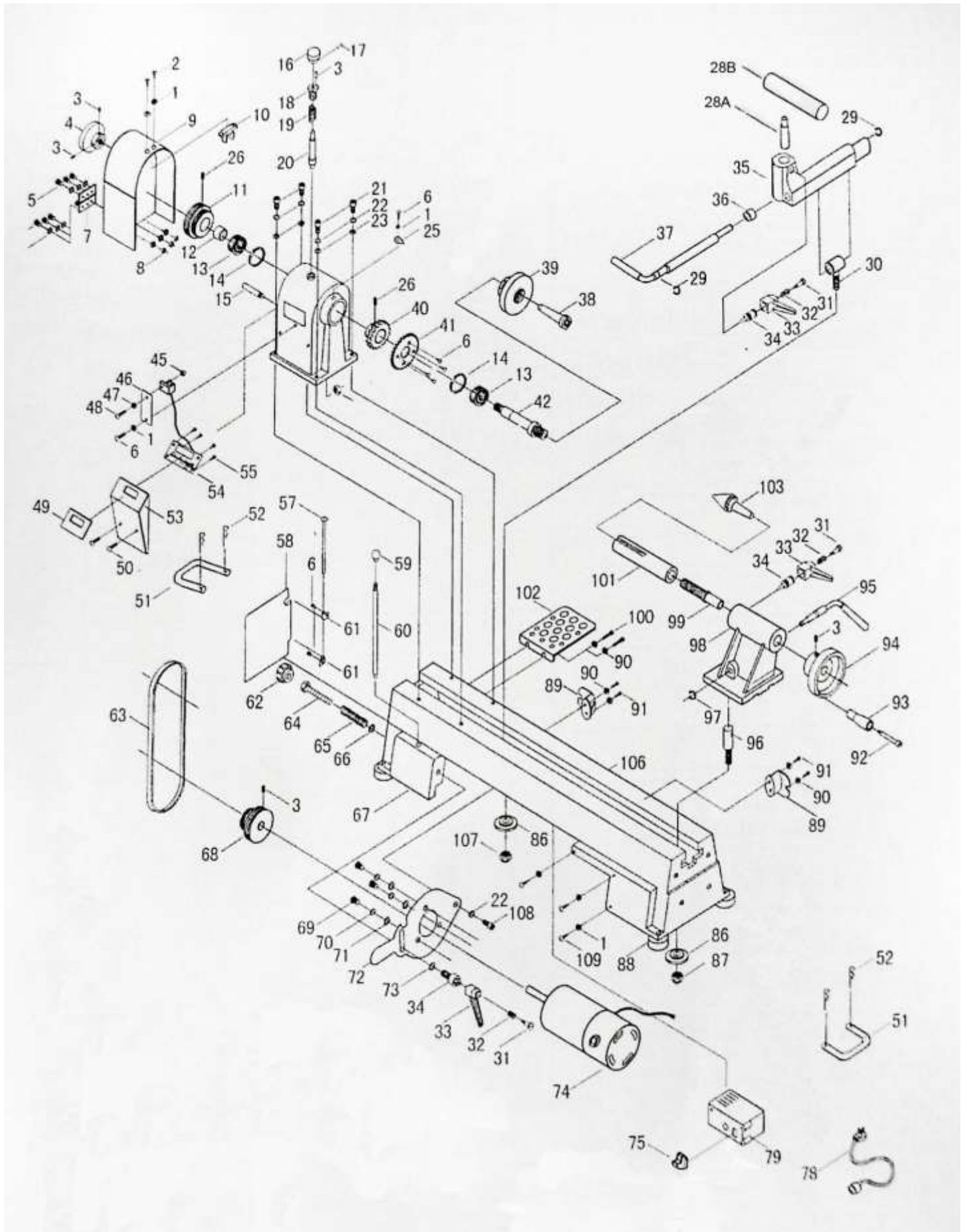



Woodworking machinery at its best!

Updated October 2016

**Charnwood, Cedar Court, Walker Road,
Hilltop Industrial Estate, Bardon Hill, Leicestershire, LE67 1TU**

**Tel. 01530 516 926 Fax. 01530 516 929
email: sales@charnwood.net website: www.charnwood.net**