

Charnwood

CHISEL MORTICER MODEL: W308

INSTRUCTION MANUAL



FOR YOUR SAFETY:

Please read this manual carefully before operating the machine and retain it for future reference.

Charnwood, 1 Rowan Street, Leicester, LE3 9GP, England

Tel: +44 (0) 116 251 1550 Fax: +44 (0) 116 253 2891

e-mail: charn@webleicester.co.uk

ZSJ A MORTISING MACHINE
PACKING LIST

No.	Description	Size	Unit	Quantity
1	Mortising machine main body			1
2	Guide plate component			1
3	Wood base plate			1
4	Bar			1
5	Bracket			1
6	Clamp			1
7	Drill clampspindle			1
8	Chuck	13mm		1
9	Chuck spanner	40, 70	each	1
10	Hexagon socket spanner	s6, s5, s3	each	1
11	Lock knob			2
12	Lock washer	8		2
13	Hexagon socket head cap screws	M8X18		2
14	Cross recessed countersunk head screws	M8X25		2
15	Instruction manual			1

Packer _____

Checker _____

I FEATURES

ZSJ A type mortising machine is a kind of light duty woodworking machine. It's faster and more accurate than drill press conversion kits with easier layout for professional mortise and tenon joints in furniture, cabinets and ect. Fence with hold down clamp can keep workpiece from lifting off the table. It's specialized with novel construction, easy operation, universal usage and reliable safety.

II. SPECIFICATIONS

1. Mortising Width:	1/4", 3/8", 1/2" (6.35, 9.525, 12.7MM)
2. Max. Mortising Depth:	3" (76MM)
3. Drill chuck capacity:	1/2" (13MM)
4. Table Size:	13-9/16"x5-13/16"
5. Base Size:	10"x7-3/4"
6. Vert Spindle Travel	3"
7. Spindle To Fence (Max.):	3-3/4"
8. Chisel To Table (Max.):	5"
9. Motor:	375W(1/2HP)
10. Over Dimension:	515x235x315MM
11. Gross Weight:	26.50KGS

III. ASSEMBLY

PLEASE REFER TO THE ASSEMBLY DIAGRAM ON PAGE 2.

1. Open the box and take out the main body and all spare parts.
2. Assemble the main body suitably on the holders with 2xM10 bolts, nuts and

PLEASE REFER TO THE ASSEMBLY DIAGRAM ON PAGE 2.

1. Open the box and take out the main body and all spare parts.
2. Assemble the main body suitably on the holders with 2xM10 bolts, nuts and washers.
3. Put bar(24) in the hole of gear shaft(20), tightening with screw(19).
4. Take the motor(29) from motor box. Fix chuck(34) onto the motor spindle.
5. Clean the grease on base(3), toothed shaft(15), guidance axis(16) and other parts with gauze dipped in gasoline or keronec.
6. Assemble the motor(29) with chuck on the elevator device(23) and tighten them by screw M6X15.
7. Fix wood base plate(6) on the base(3) with screw(7). Fix bracket(4) on the base(13) with screw(5).
8. Fix guide holder(11) and guide plate(9) to the guiding groove on the bracket(4) with lock knob(12) and washer(10).
9. Fix clamp(8) on the guiding holder(11) with another lock knob(12) and washer(10).
10. According to the rated voltage on the name plate(35), plug machine to your socket with earth line.

11. Turn on the switch(31). Look at the top of the motor, It must run clockwise.
If not, please ask the seller for amendment or replacement.

IV. USAGE

1. MORTISING

- a) Put chisel in chisel bushing(38) closely. Rotate the chisel to make the chisel groove on left or right side ,then tighten it with screw(37)

- b) Assemble the bit

Take off the left or right guard cover (39). Fix the suitable bit on the chuck(34) through the chisel hole. Drill bit must be 2 to 5mm lower than chisel bit. Then tighten drill bit with chuck spanner.

Make sure to tighten the bit and put back the guard cover(39).

See Fig. 2.

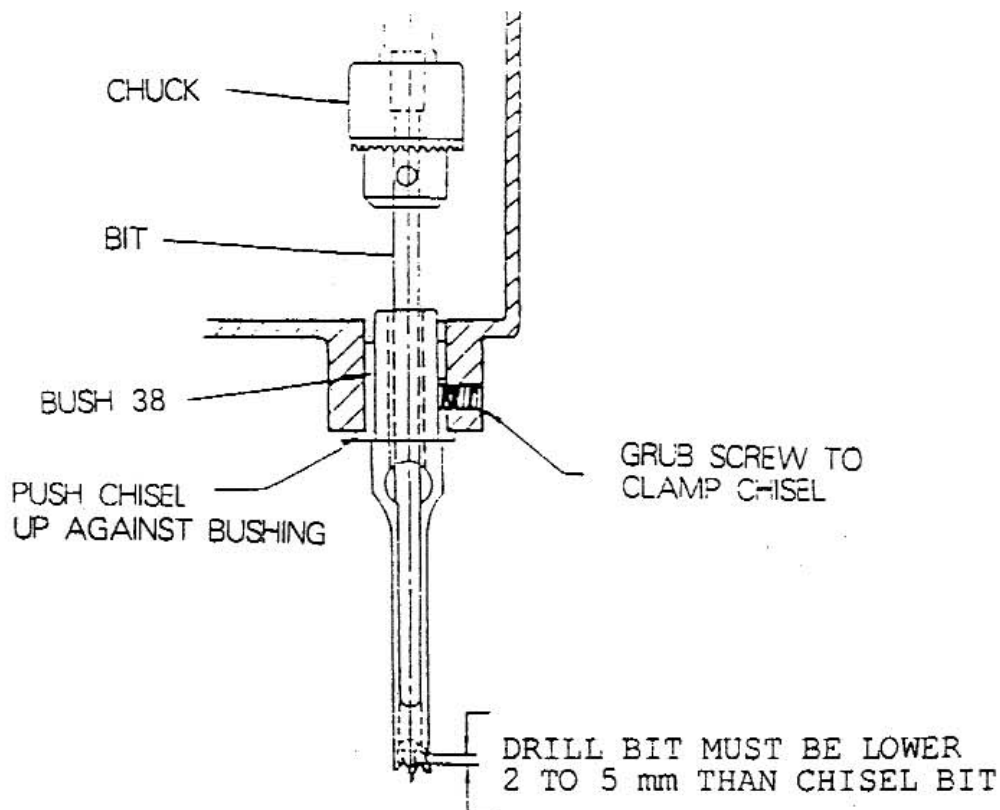

FIG. 2 INSTALLATION ON CHISEL AND DRILL BIT

- c) Adjust height of spacing sleeve

Loose fix -- position -- knob(17), press down bar(24),make elevator device move down. When the chisel bit reach the depth of the

chisel slot, raise spacing sleeve(18) to connect with elevator device(23), then tighten the fix - position - knob(17). Loose bar (24) and make elevator device move back to the original position. When drilling through the chisel slot, a piece of wood plate of about 10mm thickness should be fitted under the timber so as to avoid any damage to the wood base plate(6). At this time, please adjust the height of spacing sleeve(18) according to the thickness of the wood plate.

d) Adjust guide plate in front of rear positions.

Put the timber on wood base plate (6), press down bar(24) to make elevator device down. Move the timber and make it in correct position with chisel bit, then loose lock knob(12), and push guide plate(9) close to the timber, then tighten lock knob(12) again.

e) Adjust the height of the clamp(8).

Loose lock knob(12) on the clamp(8). Press the clamp slightly on the surface of the timber, then tighten lock knob(12) again.

f) Mortising

Turn on the switch, with left hand holding the timber, press the bar(24) by right hand to move down the elevator device(23). When drill bit reaches the timber, press with suitable strength and chips will escape freely from the chisel slot. A square mortising slot comes out on the timber. When elevator device(23) reaches the spacing sleeve(18), raise the bar(24). Move the timber to left or right and mortise it in new positions to your request. See Fig. 3.

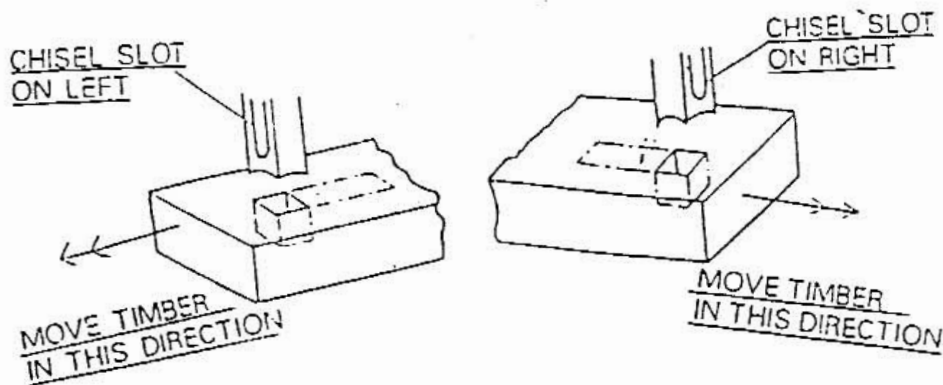

FIG. 3 MOVE TIMBER ACCORDING TO THE DIRECTION OF CHIPS ESCAPE

2. DRILLING HOLE

a) Loose chisel bushing screw(37) and take out the chisel.

b) Fit drill clamp spindle(14) and another chuck together tightly,

then fix them through the hole of the chisel bushing(38) on the drill chuck(34). Note: Not to tighten the chisel bushing screw(37), not to screw it out, otherwise the chisel bushing may fall down during your operation.

- c) Fix your drill bit on the drill chuck tightly.
- d) The adjustments of spacing sleeve(18), guide plate(9) and clamp(8) are same as mortising.
- e) Turn on the switch(31). With left hand holding the timber, press bar(24) down to drill holes by right hand.

V. SAFETY INSTRUCTIONS

FOR YOUR OWN SAFETY, PLEASE READ THE INSTRUCTION MANUAL BEFORE OPERATION AND KEEP THE FOLLOWING POINTS IN MIND.

1. Plug machine into standard voltage 240v 50hz(110v 60hz) according to the name plate.
2. When adjusting the machine, remember to turn off the switch. After your operation, take off the power plug and drill bit or chisel.
3. Before starting operation, grease properly guidance axis(16) chisel bushing(38) and toothed shaft(15).
4. When mortising or drilling, do not press down the bar too hard so as to avoid any damage to motor and cutting tools.
5. If the timber is too long, hold the timber outside the machine to avoid accidents or any damage to the machine.
6. Sharpen chisel and drill bit on time so as to keep them sharp. Please see details in VI.

VI. SHARPENING CHISEL AND DRILL BIT

1. SHARPENING THE CHISEL

- a) Sharpening is required when chisel bits are of brad point, spur or cutting lip becomes dull or blunk.
- b) Put chisel bit into soft vise jaws. To avoid damage to the chisel, do not over tighten the jaw.
- c) Fit cutter into brace and place it to end of the chisel as shown in Fig. 4. Please fit correct pilot in cutter and tighten grub screw.
- d) Press tool cutter properly onto chisel. Turn 2-3 rounds of the brace and sharpen the chisel. If chisel bit is still not sharp enough, do the same again until the bit is sharp enough.
- e) If you have no sharpening tool as shown in Fig. 4, a tapered sand

stone disc would be helpful. Fix it on an electric drill and sharpen the bit slowly.

- f) If the cutter edge protruded, sharp it carefully with a small file.
- g) Remove chisel from vice jaws. Use a fine slip stone to remove any burrs from outer face of the chisel so as to make the chisel much sharper.

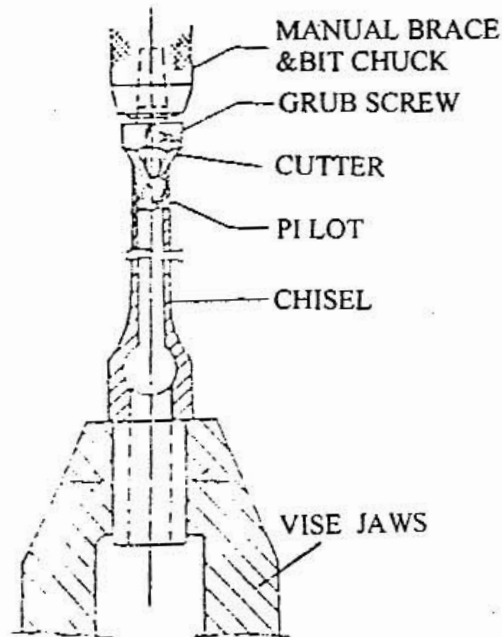

FIG. 4 SHARPENING THE CHISEL

2. SHARPENING DRILL BIT (See Fig. 5)

- a) File bit's cutter edge.
- b) File inner edge of spur.
- c) With a fine slip stone remove edges, make it much sharper.

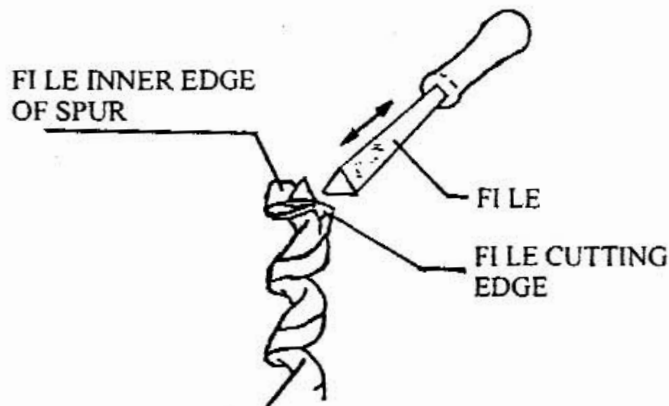

FIG. 5 SHARPENING THE DRILL BIT