

# Charnwood

*Woodworking machinery at its best!*

**8" CAST IRON SAWBENCH  
WITH SLIDING CARRIAGE  
OPERATING INSTRUCTIONS**

**MODEL: W618**



**CE**

**Charnwood, Cedar Court, Walker Road, Bardon Hill, Leicestershire,  
LE67 1TU**

**Tel. 01530 516926 Fax. 01530 516929**

**email; sales@charnwood.net website; www.charnwood.net**

# Introduction

To get the most out of your new table saw, please read through this manual and safety instructions before use. Please also save the instructions in case you need to refer to them at a later date.

## Technical data

Voltage/frequency	230 V ~ 50 Hz
Motor (Induction)	1100 watts
Table size	535mm x 400mm
Table size with extension table	535mm x 1000mm
Saw blade diameter	200mm
Bore size	30mm
Maximum depth of cut at 90 degrees	60mm
Maximum depth of cut at 45 degrees	40mm
Cutting width with extension table	750mm
Net weight	69kg

## Main components

- |                      |                     |
|----------------------|---------------------|
| A. On / Off Switch   | E. Guide fence      |
| B. Raising Handwheel | F. Mitre guide      |
| C. Tilting handwheel | G. Blade guard      |
| D. Extension table   | H. Sliding carriage |

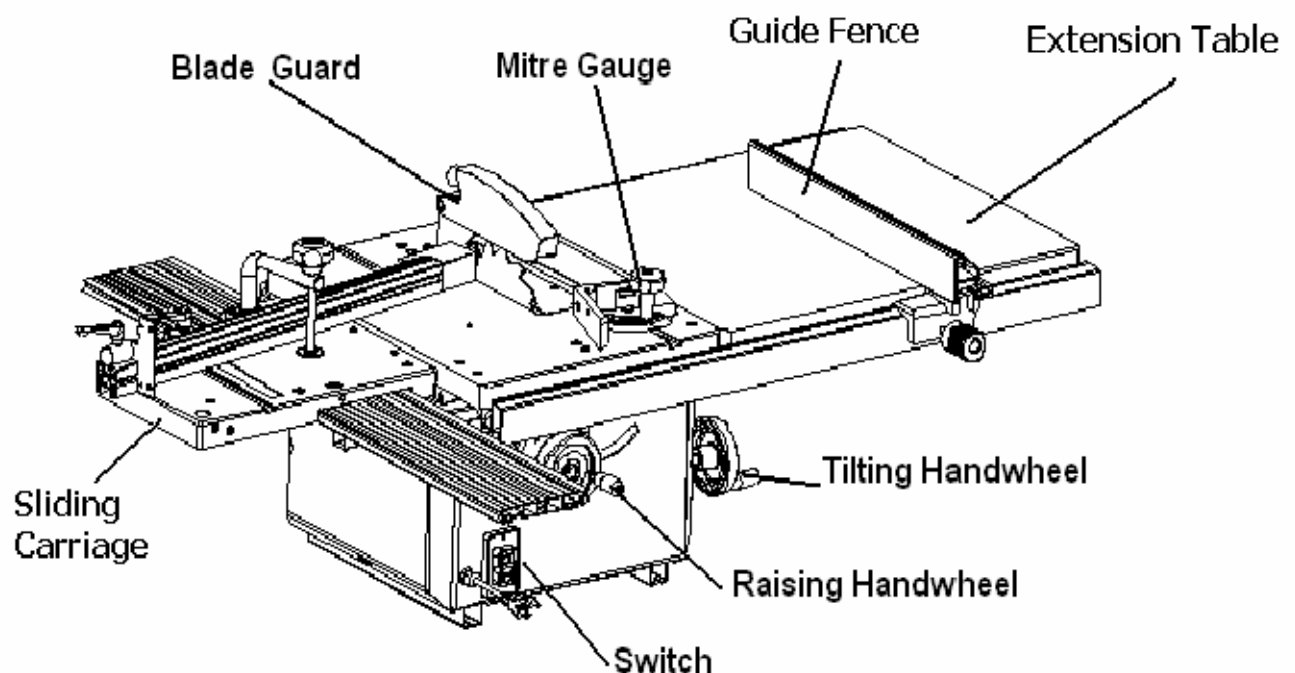

## Safety Rules

As with all machines, there is a certain amount of hazard involved with the use of this circular saw-bench. Use the machine with the respect and caution demanded where safety precautions are concerned. When normal safety precautions are overlooked or ignored, personal injury to the operator can result.

Read, understand and follow the safety and operating instructions found in this manual. Know the limitations and hazards associated with this circular sawbench.

**Electrical grounding.** Make certain that the machine frame is electrically grounded and that a ground lead is included in the incoming electrical service. In cases where a cord and plug are used, make certain that the grounding plug connects to a suitable ground. Follow the grounding procedure indicated in the local electrical code.

**Eye safety.** Wear an approved safety shield, goggles, or glasses to protect eyes. (NOTE: Common eye glasses are not safety glasses.)

**Personal protection.** Before operating the machine, remove tie, rings, watch and other jewelry and roll up sleeves above the elbows. Remove all loose outer clothing and confine long hair. Protective type footwear should be used. Do not wear gloves.

**Guards.** Keep the machine guards in place for every operation for which they can be used. If any guards are removed for maintenance, DO NOT OPERATE the machine until the guards are re-installed.

**Work area.** Keep the floor around the machine clean and free of scrap material, saw dust, oil and other liquids to minimize the danger of tripping or slipping. Be sure the table is free of all scrap, foreign material and tools before starting to cut. Make certain the work area is well lighted and that a proper exhaust system is used to minimize dust. We recommend the use of anti-skid floor strips on the floor area where the operator normally stands and that each machine's work area is marked off. Provide adequate work space around the machine.

**Operator position.** Maintain a balanced stance and keep your body under control at all times. Do not stand in line with the saw blade or work piece and do not allow anyone else to do so. Never climb on or near the saw.

**Do not overreach.** Use a support table or have a helper or "tailman" take stock away from the back side of the blade.

**Housekeeping.** Before turning on machine, remove all extra equipment such as keys, wrenches, scrap, and cleaning rags away from the saw.

**Careless acts.** Give the work you are doing your undivided attention. Looking around, carrying on a conversation, and "horseplay" are careless acts that can result in serious injury.

Disconnect machine before performing any service or maintenance or when changing blades. A machine under repair should be RED TAGGED to show it should not be used until the maintenance is complete.

**Alignment.** Check the alignment of the splitter, fence and miter slot to the blade. A caution decal is installed on each guard and splitter to remind the operator of the dangers of mis-alignment.

**Maintain tools in top condition.** Check the saw blade for cracks or missing teeth. Do not use a cracked or dull blade or one with missing teeth or improper set. Make sure the blade is securely locked on the arbor.

**Hand safety.** Keep hands clear of the blade area. Do not reach past the blade to clear parts or scrap with the saw blade running. Never saw free hand. Avoid awkward operations and hand positions where a sudden slip could cause your hand to contact the blade.

**Safety devices.** Always use the splitter, blade guard, push stick and other safety devices for all operations where they can be used. On operations such as dadoing or molding where the blade guard cannot be used, use feather boards, fixtures and other safety devices and use extreme caution. Reinstall the splitter and blade guard immediately after completing the operation that required their removal.

**Saw blade rotation.** Be sure the saw blade rotates clockwise when viewed from the motor side (left side) of the machine.

**Adjustments.** Make all adjustments to the machine and operational setup with the power off. Never remove the insert with the blade running.

**Material condition.** Do not attempt to saw boards with loose knots or with nails or other foreign material, on its surface. Do not attempt to saw twisted, warped, bowed or "in wind" stock unless one edge has been jointed for guiding purposes prior to sawing.

**Large stock.** Do not attempt to saw long or wide boards unsupported where spring or weight could cause the board to shift position.

**Job completion.** If the operator leaves the machine area for any reason, he should turn “off” the power to the table saw motor and wait until the saw blade comes to a complete stop before his departure. In addition, if the operation is complete, he should clean the table saw and the work area. NEVER clean off the table saw with power “on” and NEVER use the hands to clear sawdust and debris; use a brush. If you are not thoroughly familiar with the operation of this circular sawbench, obtain advice from your supervisor, instructor or other qualified person.

**Drugs, alcohol, medication.** Do not operate this machine while under the influence of drugs, alcohol, or any medication.

**Health hazards.** Some dust created by power sanding, sawing, grinding, drilling and other construction activities contains chemicals known to cause cancer, birth defects or other reproductive harm. Some examples of these chemicals are:

- \* Lead from lead-based paint.
- \* Crystalline silica from bricks and cement and other masonry products.
- \* Arsenic and chromium from chemically-treated lumber.

Your risk from these exposures varies, depending on how often you do this type of work. To reduce your exposure to these chemicals, work in a well-ventilated area, and work with approved safety equipment, such as those dust masks that are specifically designed to filter out microscopic particles.

**Use proper extension cord:** Make sure your extension cord is in good condition. When using an extension cord, be sure to use one heavy enough to carry the current your product will draw. An undersized cord will cause a drop in line voltage resulting in loss of power and overheating. If in doubt, use the next heavier gauge the smaller the gauge number, the heavier the cord.

### **General Safety Procedures for Table Saw**

This machine has been built exclusively for woodworking. Do not alter the design of the machine or use it for purposes not intended by the manufacturer. The manufacturer is not liable for damage or injury, which results from incorrect assembly, operation or electrical connections. This machine must be operated under strict safety regulations. This is the only way to reduce the risk of accidents.

#### **Location**

Certain types of woods, press boards, etc. produce hazardous dust emissions when being processed. For this reason, processing procedures must be performed with an exhaust unit (air speed at the connection points: 20m/s) Be sure to switch on the machine and the exhaust unit simultaneously. The main cable plug must be connected as appropriate for the electrical installation and must have an earth lead (or a directly earth conductor for 380 V). It is advisable to have a qualified electrical connection. Appropriate lighting must be provided in the work area.

#### **The Operator**

Read the operating manual carefully to prevent machine accidents. Never work while under the influence of drugs, alcohol or medications. Wear tight-fitting work clothes, safety goggles and safety shoes and tie back long hair. Remove rings, wrist watches and bracelets before working.

Ear protection is recommended. Never climb onto the machine table: the machine may fall and cause injuries.

Keep children and visitors out of the work area.

#### **Before working**

Check that the sawing tool type is suited for the intended work. Immediately replace damaged or dull sawing tools. Only work with the appropriate standard accessories. Always work with well-sharpened sawing tools increase the risk of wood kick back. Note the correct rotational direction. As a general rule, check that sawing tool wrenches and other items have been removed. Check that the sawing tool can rotate freely and does not contact the limit stop, the safety equipment, the work piece or other objects. Keep out of the kick-back zone.

**While working**

Wood must be hand fed uniformly and without jerking into the sawing tool, slightly more slowly when processing hard wood or work pieces, which produce large amounts of dust. Never move the work piece during a processing operation. Avoid uncomfortable working stances to reduce the risk of contacting the rotating sawing tool. Do not bend over the rotating sawing tool. Remove debris from the machine table only when the machine is off. Never use the machine table as a worktable while the sawing tool is rotating.

**After working**

Never leave the machine operating without supervision. Remain at the machine until the sawing tool has come to a complete stop. Remove debris and clean the machine and surrounding area so that the machine is ready to use the next time.

**Machine maintenance**

Unplug the mains cable before any mechanical or electrical work is performed or when the sawing tool is changed. Regularly lubricate mechanical parts: threaded rods, gears, driving chains, hinges, sliding parts, etc.

**Grounding Instructions**

Caution: This tool must be grounded while in use to protect the operator from electric shock.

In the event of a malfunction or breakdown, grounding provides a path of least resistance for electric current to reduce the risk of electric shock. This tool is equipped with an electric cord having an equipment-grounding conductor and a grounding plug. The plug must be plugged into a matching outlet that is properly installed and grounded in accordance with all local codes and ordinances.

Do not modify the plug provided. If it will not fit the outlet, have the proper outlet installed by a qualified electrician.

Improper connection of the equipment-grounding conductor can result in a risk of electric shock. The conductor, with insulation having an outer surface that is green with or without yellow stripes, is the equipment-grounding conductor. If repair or replacement of the electric cord or plug is necessary, do not connect the equipment-grounding conductor to a live terminal.

Check with a qualified electrician or service personnel if the grounding instructions are not completely understood, or if in doubt as to whether the tool is properly grounded. Use only three wire extension cords that have three-prong grounding plugs and three-pole receptacles that accept the tool's plug.

Repair or replace a damaged or worn cord immediately.

## ASSEMBLY INSTRUCTIONS

- Using M8 X 12mm coach bolts and M8 nuts bolt together two 'A' frames using two legs, one long strut in the middle and a short strut at the top (Fig.1 and Fig.2).

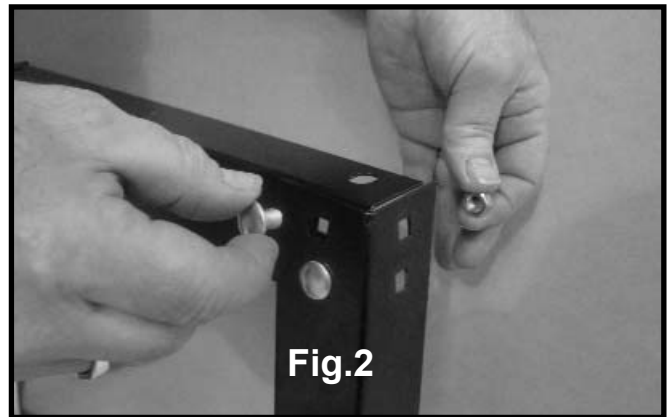
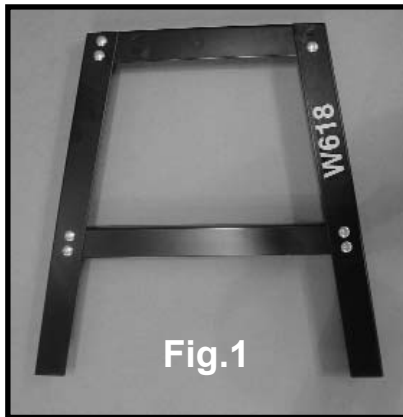

- Join the two 'A' frames together using the remaining long bars in the middle and two short bars at the top (Fig.3).

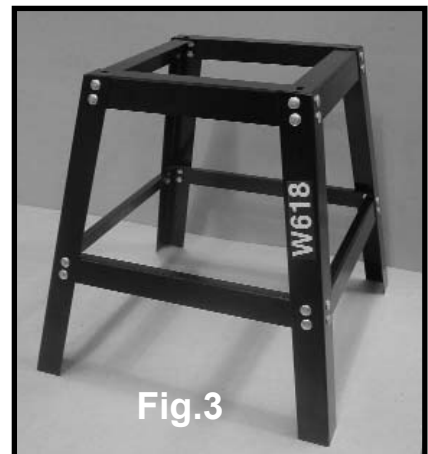

- Fit the four rubber feet to the bottom of the legs (Fig.4).

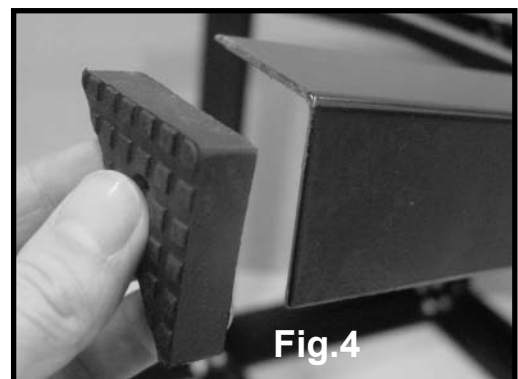

- Place the saw table on the stand, lining up the slots in the base of the saw table with the holes on the top of the stand. Bolt in place using 4 off M8 Hexagan head bolts and 4 off M8 nut (Fig.5)

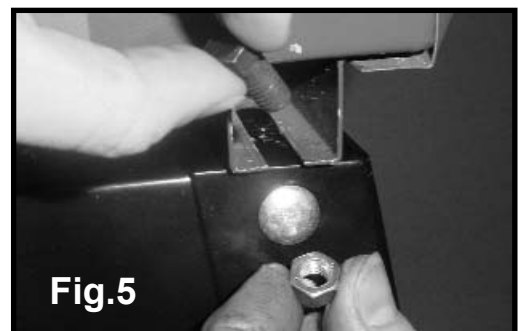

- Attach the two sliding carriage support arms to the underside of the cast iron saw table using 4 off M6 x 50mm countersunk bolts and 4 off M6 nut and washer (Fig.6)



- Place an M6 x 16mm hexagen head bolt in each of the 4 clearance holes on the two support arms and loosely put an M6 nut and washer on the bottom of each (Fig.7)

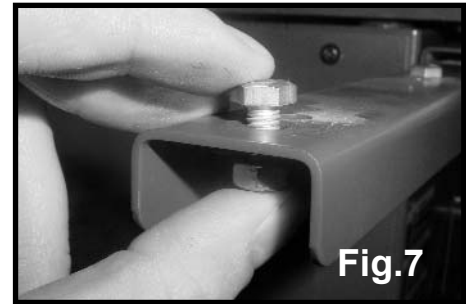

- Slide the extruded carriage arm onto the four M6 x 16mm bolts (Fig.8)

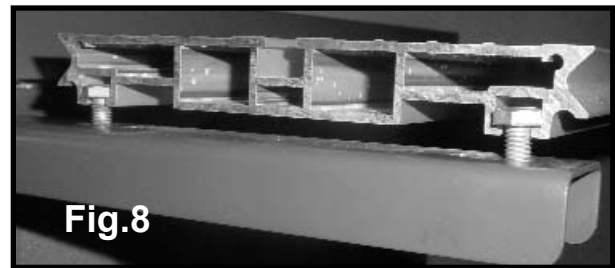

- Slide the sliding carriage table onto the extruded arm and then using a straight edge across the sliding table and the saw table fit and adjust the four M6 x 30mm hexagen head bolts until the sliding table is approximately 0.5mm above the saw table (Fig.9,10,11).

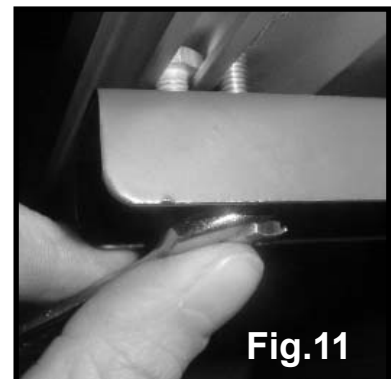
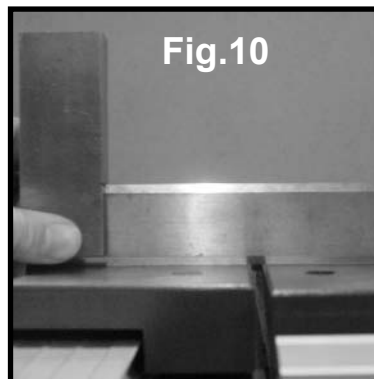
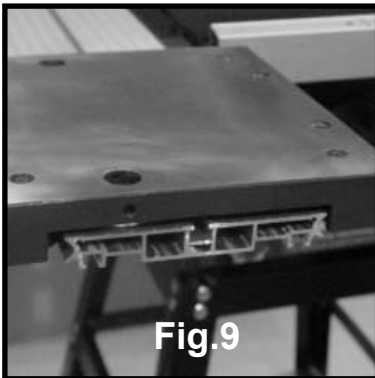

- When the level is set correctly tighten the four M6 nuts on the M6 x 16mm hexagen head bolts underneath the extruded arm on the suport arms (Fig.12)



- Fit an end stop in each end of the extruded carriage arm (Fig.13).

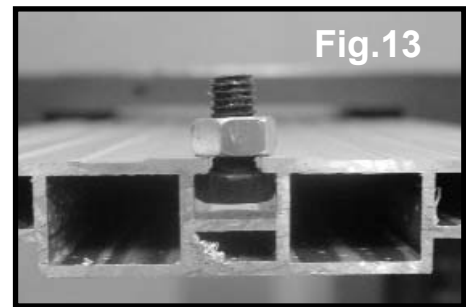

- Slide the two connecting blocks into the T-slot on the angled fence making sure the clamp block is slid in first (Fig.14).

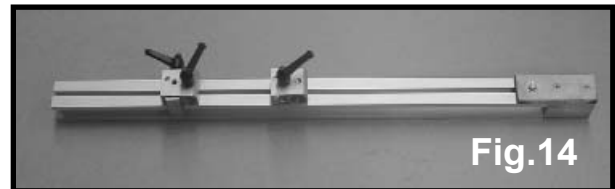

- Slide the T-bolt of the left hand connecting block into the T-slot of the sliding carriage table (Fig.15).

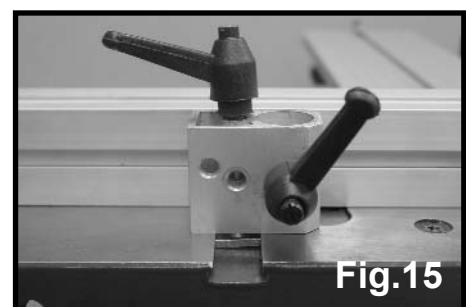

- Line up the clamp connecting block with the front 20mm diameter hole in the sliding carriage table (Fig.16), then fit the clamp arm into place and tighten the grub screw in the side of the sliding carriage table (Fig.17).

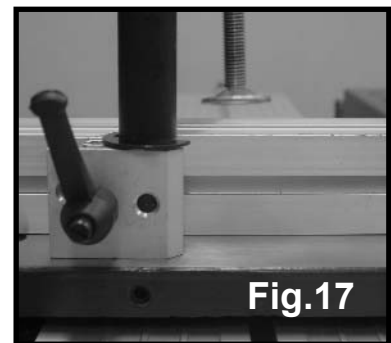
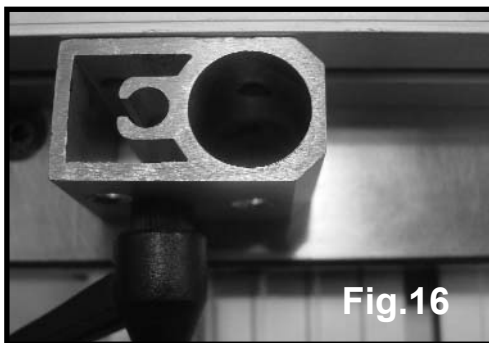

- To set the fence to 90 degrees press the stop up on the front eccentric bush and push the angle fence up against the stop (Fig.18) making sure the wooden block on the end is just missing the blade. Check the 90 degree angle is correct then lock off the kipp handles in both connecting blocks (Fig. 19 & 20).

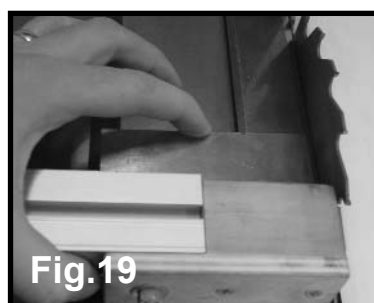



- If the angle fence is not set at 90 degrees then undo the grub screw in the side of the sliding carriage table and using a flat screwdriver turn the eccentric bush until the angle is correct then tighten the grub screw (Fig21 & 22).

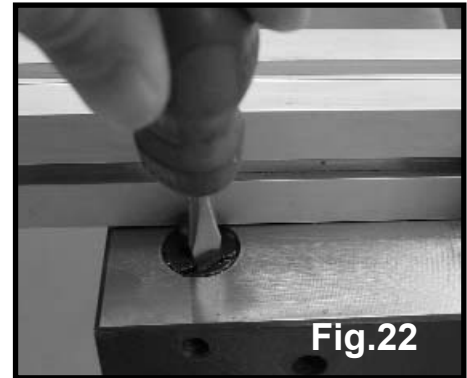
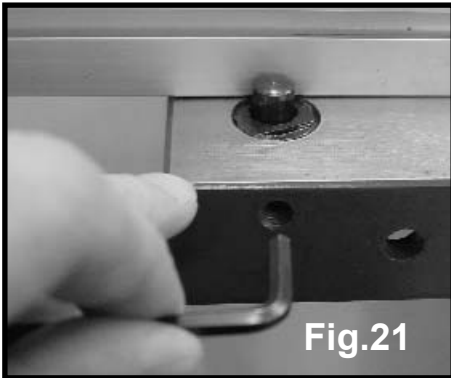

- To set the angle fence to angles between 45 and 90 degrees undo the 3 kipp handles and slide the fence to the required angle on the scale on the sliding carriage table and lock off the 3 kipp handles (Fig.23).

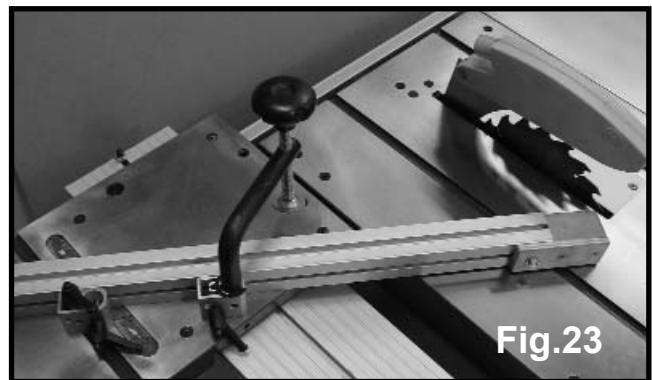

- Slide the flip over stop into the T-slot on top of the angled fence (Fig. 24).

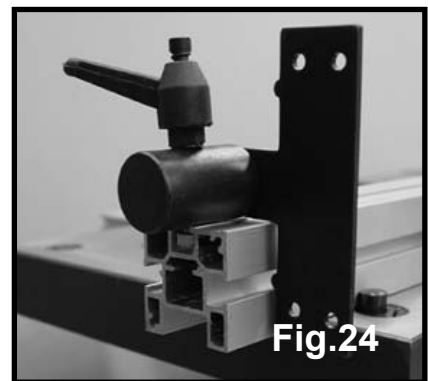

- The fence can also be used at the rear of the sliding carriage table if you prefer to push the timber against the fence at the front (Fig.25).



- Place an M6 x 30mm domed pozi head screw and washer in the 3 holes in the front and rear of the main table. Attach an M6 square nut to each. Slide the extruded support arms onto the nuts so that the nut sits in the T-slot (Fig.26, 27, 28, 29).

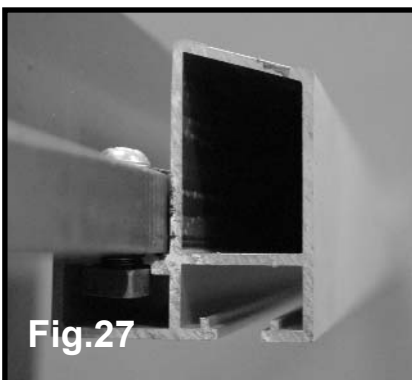
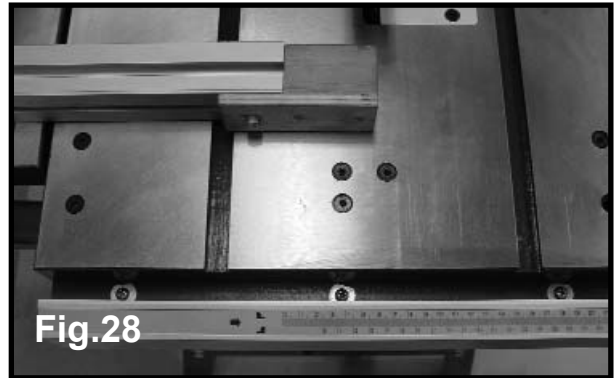
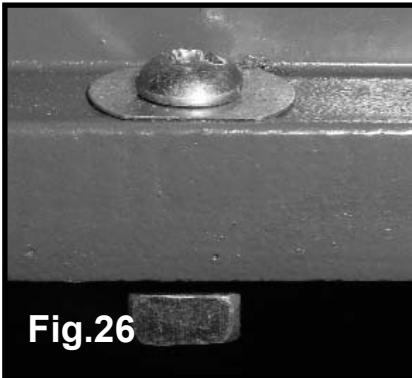

- The extension table is supplied with several M6 shim washers to allow you to set the height level with the main table (Fig.30). Place an M6 x 15mm domed pozi screw with washer into each of the 6 holes on the extension table lip. Put the required number of shim washers onto the screws and hold in place using an M6 nut. Screw the nut on so there is a 2mm gap between the nut and shim washers (Fig.31).

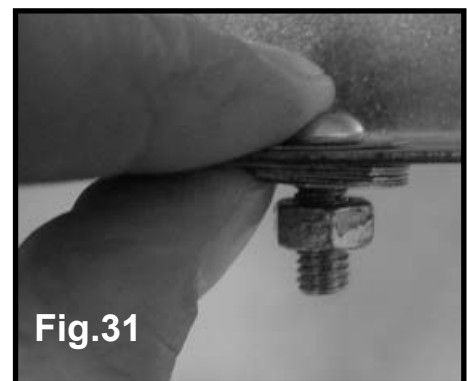
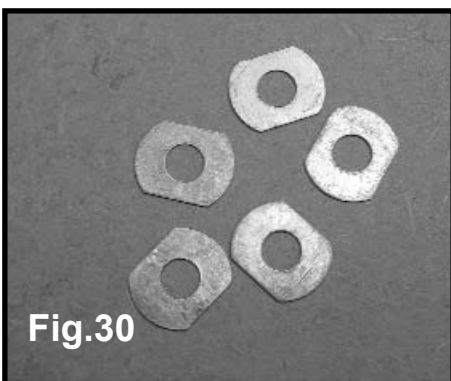

- Slide the extension table into place sliding the M6 nut into the support arms T-slot making sure the shim washers are on top of the extrusion. Slide all 6 nuts and screws into place and tighten (Fig.32 & 33).

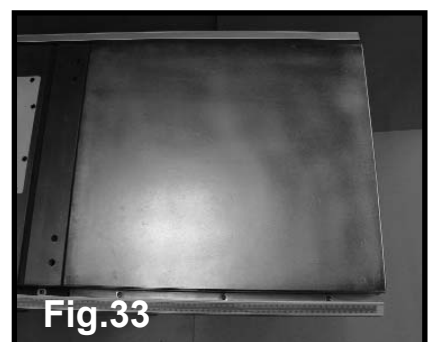
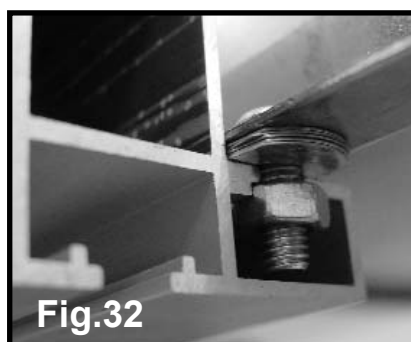

## OPERATING INSTRUCTIONS

### Mounting and adjusting the Riving Knife

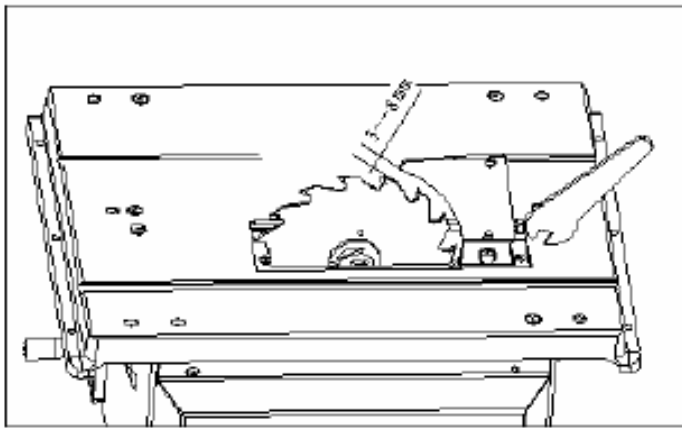

**Fig.34**

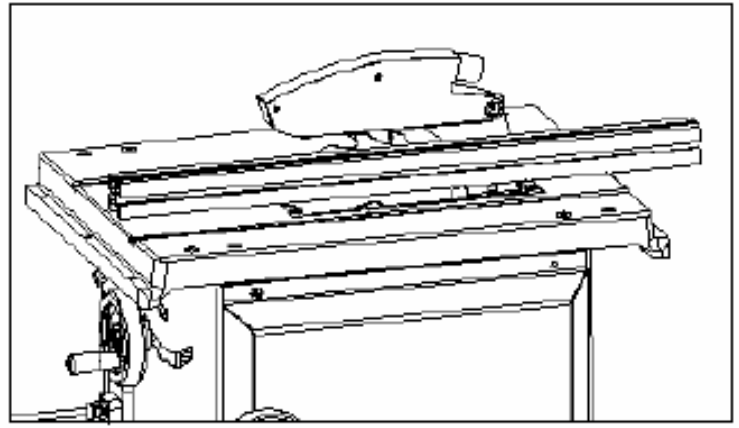

**Fig.35**

Loosen the flange base with a 13 mm wrench and insert the riving knife. Adjust the riving knife and be sure to maintain a distance of approx. 3mm to the saw blade (Fig. 34). Securely fasten the riving knife with screw. Check that the riving knife is parallel to the saw blade by means of the table insert (Fig. 35).

### Adjusting the Rip Fence

The scale must be adjusted so that it reads the correct value. Set the fence to zero and lock it in place. Undo the six pozi screws slightly allowing the scale to be adjusted left or right as required. You may need to readjust this when changing to a blade of different width.

Next check the fence is parallel to the sawblade. Use the slots for the mitre fence as an optical guide. It can be adjusted using the same six pozi screws.

(Fig. 36) & (Fig. 37).

The fence itself can be fitted in two different ways depending on the type of work to be cut. To change the fence undo the hex head bolt underneath the fence (Fig. 38)

(Fig. 39) & (Fig. 40) show the two fence positions. Set up the fence as shown in Fig. 39 to make small or thin cuts.

The rip fence can be used on the left or the right side of the saw blade.

NOTE: Regularly check that the fence is parallel to ensure perfect cutting.

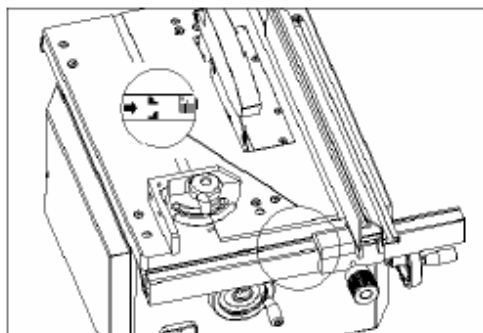

**Fig.36**

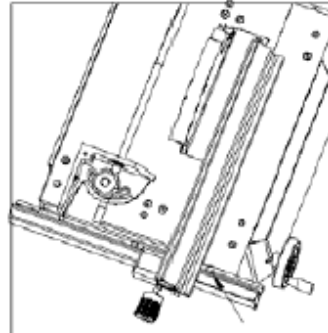

**Fig.37**

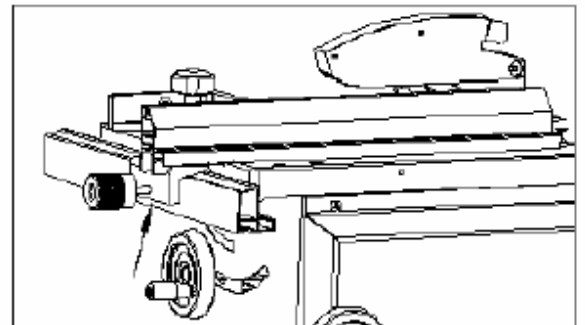

**Fig.38**

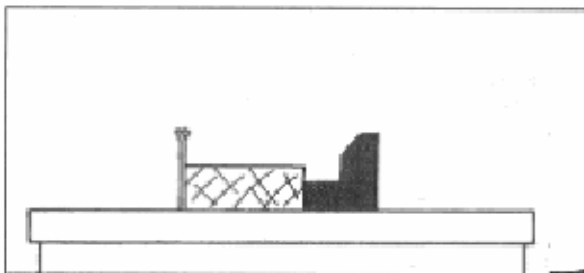

**Fig.39**

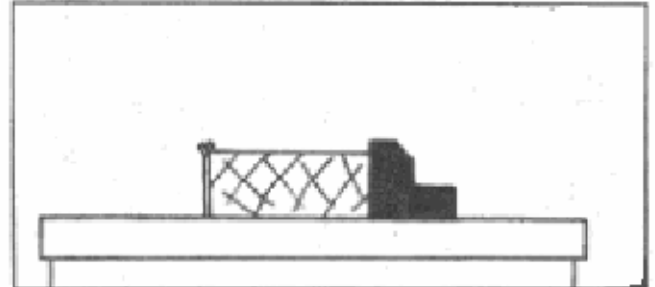
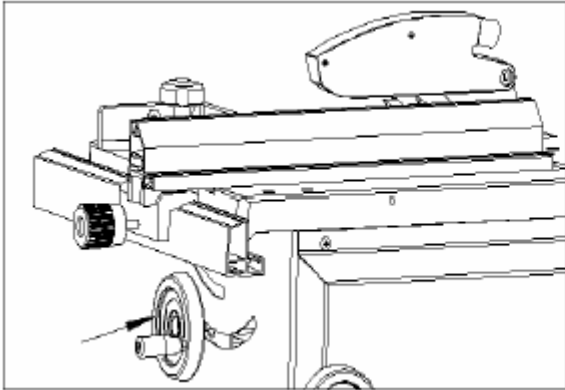

**Fig.40**

### Adjusting the cutting height

Adjust the height with the hand wheel (Fig. 41)

Select a cutting height such that the saw blade teeth still protrude from the work piece to be cut. (Fig.42)



**Fig.41**

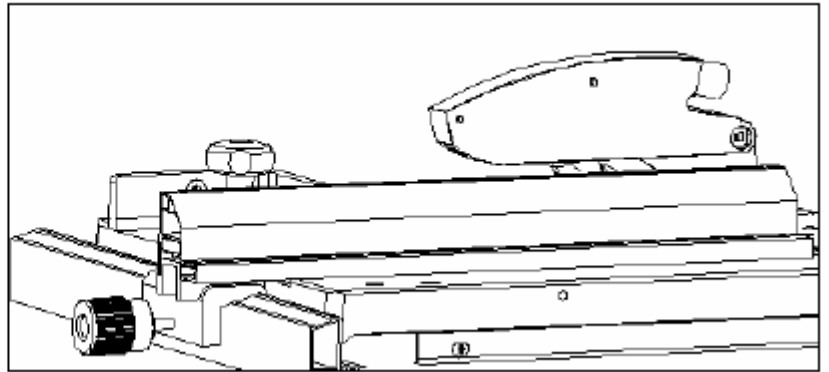
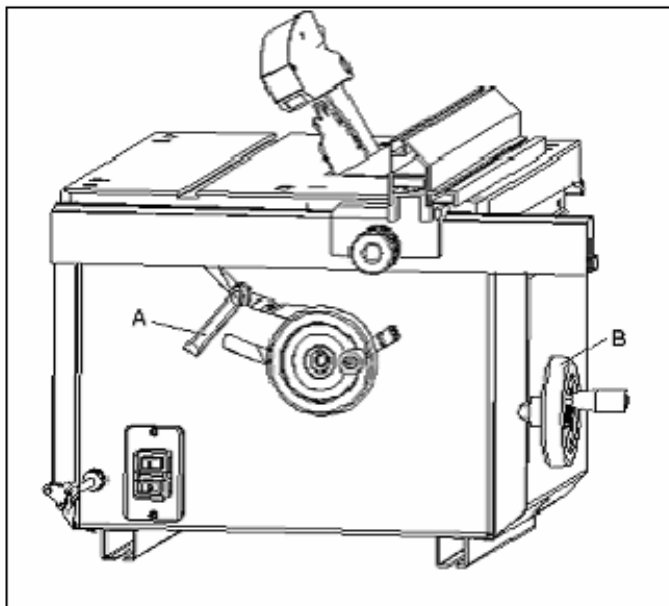

**Fig.42**

### Adjusting the Blade Angle

Release the lock knob A (Fig.43). The saw blade can be tilted by up to 45° by rotating hand wheel B (Fig.43). Once the desired angle is achieved lock the angle using lock knob A.

**Note:** The maximum depth of cut is reduced by 10 mm at angles of 30° or more.



**Fig.43**

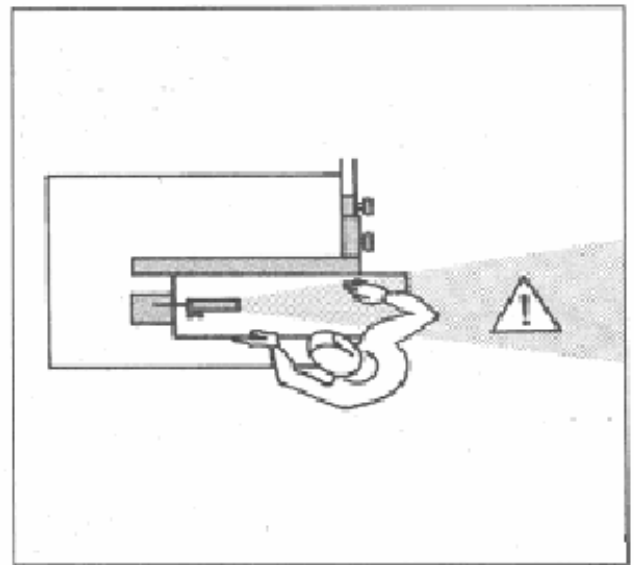

**Fig.44**

### Working with the circular table saw

Only use sharp, undamaged circular saw blades. Adjust the angle of the blade. Adjust the height of the blade. Adopt a working stance as indicated in the figure. Keep out of the danger zone. (Fig 44)

Feed the work piece with both hands (be sure to use a push stick near the saw blade) until it is behind the riving knife. Secure longer work pieces so that they do not flip after the cutting procedure (i.e. with a table extension or roller stand). (Fig.45)

### Cutting narrower work pieces, edges and strips

Use the flat edge of the rip fence for work pieces narrower than 120 mm. Use a parallel intermediate piece if necessary. Secure longer work piece so that they do not flip after the cutting procedure

(i.e. with a table extension or roller stand). (Fig 46)

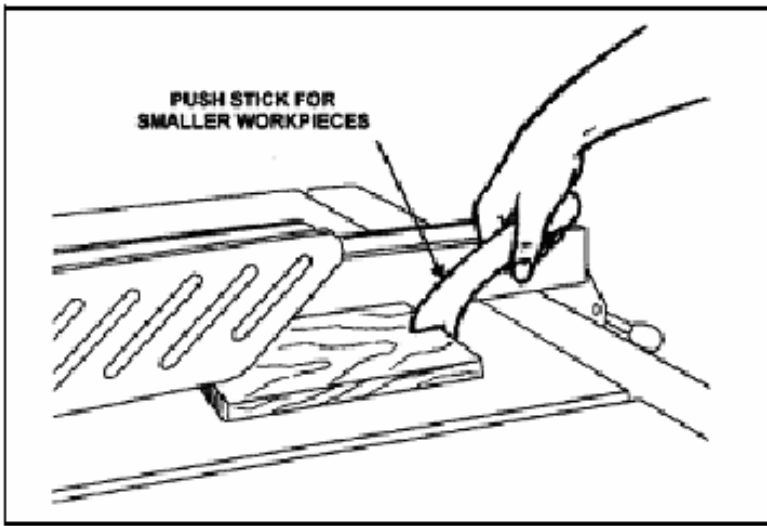

**Fig.45**

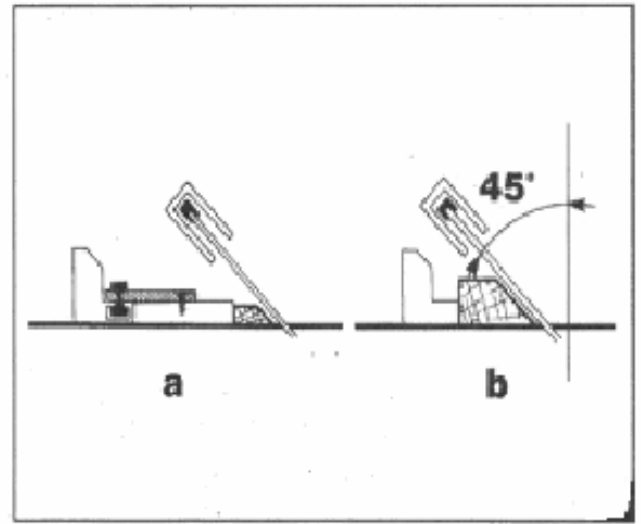

**Fig.46**

**Sliding Mitre guide**

The mitre guide can be mounted on the left or right hand side of the saw blade in the T-groove.

Diagonal cuts between 90° and 45° can be exactly made. ( Fig.47)

Diagonal positioning is made possible by the 90° orientation of the two supporting surface of the limit stop.

**Cross-cutting narrower work pieces**

Feed work pieces only with the mitre guide or sliding table. (Fig. 48)

(CAUTION: Do not remove pieces of debris from the blade area with your hands.)

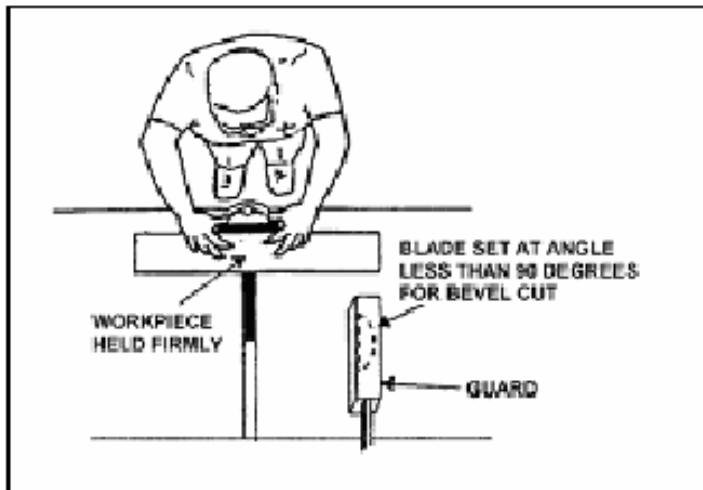

**Fig.47**

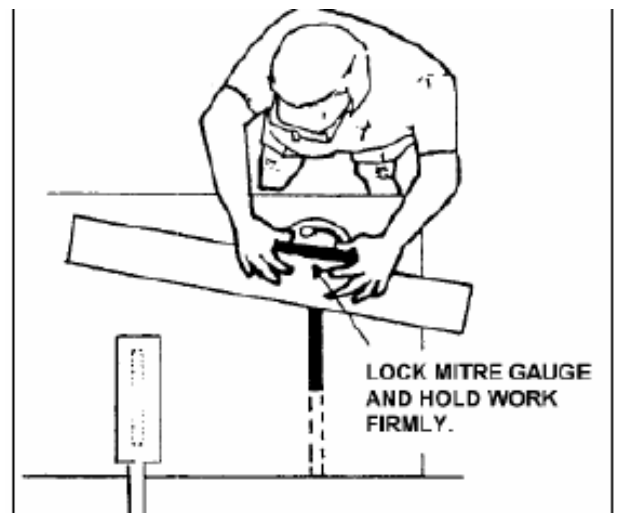

**Fig.48**

**Mitre Guide**

The mitre guide can be inserted into the machine table T-grooves on the right or left hand side of the saw blade. Cross-cuts can be made at all angles by pivoting the guide. The 90° milled angular limit stop is especially suited for exact miter cuts. See the frame-cutting example. (Fig. 49)

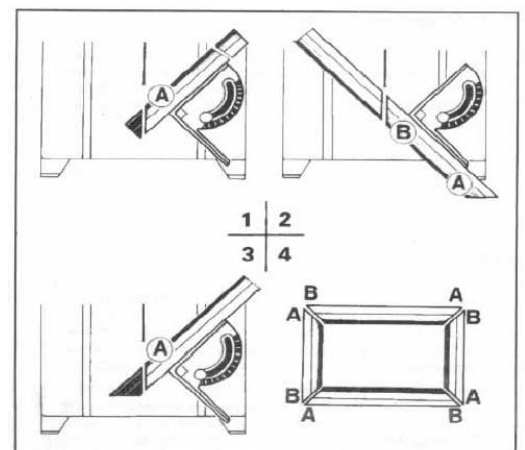

**Fig.49**

## Malfunctions

### Machine vibrates

Clamping levers for height and diagonal adjustment are not locked.

Sawing tool is not tightly screwed.

### Cuts are not clean/wood is burned

Sawblade is dull or incorrectly mounted.

Rip fence is not parallel to the sawblade.

### Rapid sawing tool wear

Sawing tool is incorrectly sharpened.

Contaminated wood (cement, sand, nails etc...).

**Motor becomes too warm** (It is too hot to touch with bare hands, it continuously shuts itself off.)

By all means have a qualified electrician inspect the motor.

### Machine comes to a stop

Drive belt is slipping and needs replacing.

Motor Overloading (feeding too rapid, sawblade is dull).

### Wood is raised by the rear side of the saw blade

Rip fence not parallel.

Riving knife is not aligned.

### The saw height is difficult to adjust

Thoroughly clean and lubricate the threaded rod, gears and slide tracks.

Check the operation of the clamping lever.

### Miscellaneous

Bearings make unusual noises. Inspect the bearings and replace if necessary.

Check the tension of the poly-v belt (poly-v belts are accessible when the exhaust cover is removed).

Please dispose of packaging for the product in a responsible manner. It is suitable for recycling. Help to protect the environment, take the packaging to the local amenity tip and place into the appropriate recycling bin.



Only for EU countries

Do not dispose of electric tools together with household waste material!

In observance of European Directive 2002/96/EC on waste electrical and electronic equipment (EEE) and its implementation in accordance with national law, electric tools that have reached the end of their life must be collected separately and returned to an environmentally compatible recycling facility.

Your local refuse amenity will have a separate collection area for EEE goods.



## Part List

Part No	Description	Q'TY	Part No	Description	Q'TY
1	Set screw	1	45	nut	2
2	Shaft	1	46	Washer	1
3	Hand wheel	1	47	nut	2
4	Pin	1	48	Sawing base	1
5	Sharp	1	49	Pin	1
6	Pin	1	50	Setscrew	1
7	Screw	1	51	Plate	1
8	Motor	1	52	nut	1
9	C-Spring	1	53	nut	1
10	Motor guidance plate	1	54	Screw	1
11	Arbor	1	55	Screw	1
12	Washer	3	56	Handwheel	1
13	Set screw	3	57	Screw M20	2
14	Set screw	2	58	Nut M20	1
15	Washer	1	59	Threaded shaft	1
16	Long plate	1	60	Plate	1
17	Washer	1	61	Plate	1
18	Nut	2	62	Set screw	12
19	Motor pulley	1	63	Base	1
20	Extractor connecting piece	1	64	SwitchBox	1
21	Washer	1	65	Switch	1
22	Set screw	1	66	Clamp for cord	1
23	Riving Knife (Splitting wedge)	1	67	Set screw	4
24	Flange	1	68	Power Cord	1
25	Washer	1	69	Washer	1
26	Set screw	1	70	Arbor	1
27	Washer	2	71	Plate	2
28	Set screw	2	72	Supporting rear	2
29	Holding plate A	1	73	Washer	2
30	Riving Knife (Splitting wedge)	1	74	Nut M20	1
31	Holding plate B	1	75	Table	1
32	Poly-V belt HR410	1	76	Cover	1
33	Spindle pulley	1	77	Screw	6
34	Set screw	2	78	Screw	4
35	Ball bearing	1	79	Pin	1
36	Ball bearing	1	80	Scale	1
37	C-Spring	1	81	Lock handle	1
38	Shaft	1	82	Stop ruler	1
39	Set screw	1	83	Plate	1
40	Protective guard	1	84	Guide	1
41	Supporting plate	1	85	Lock handle	1
42	Washer	2	86	Scale	1
43	Nut	2	87	Guide	2
44	Washer	1	88	Bolt	1

# EXPLODED VIEW

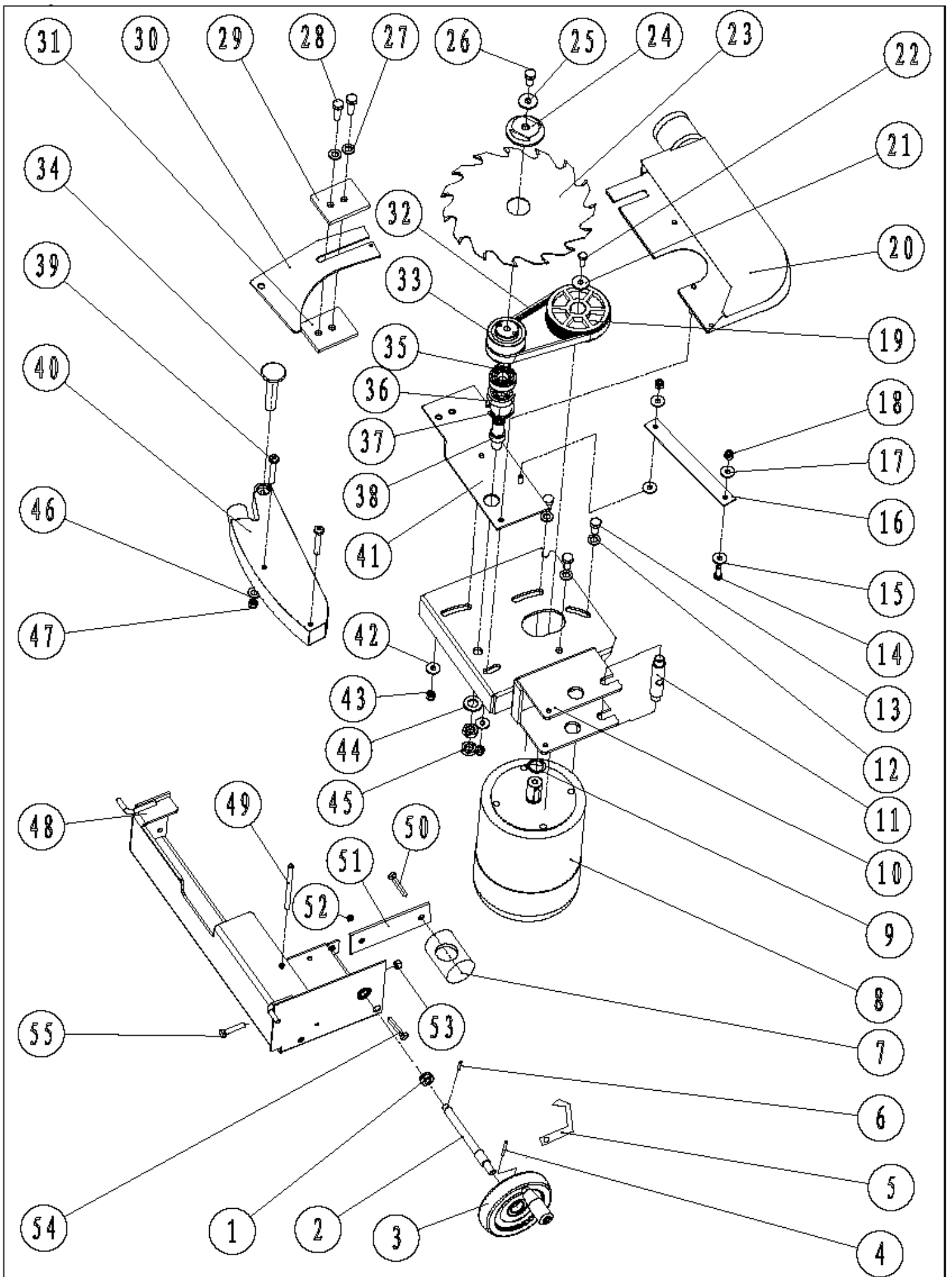



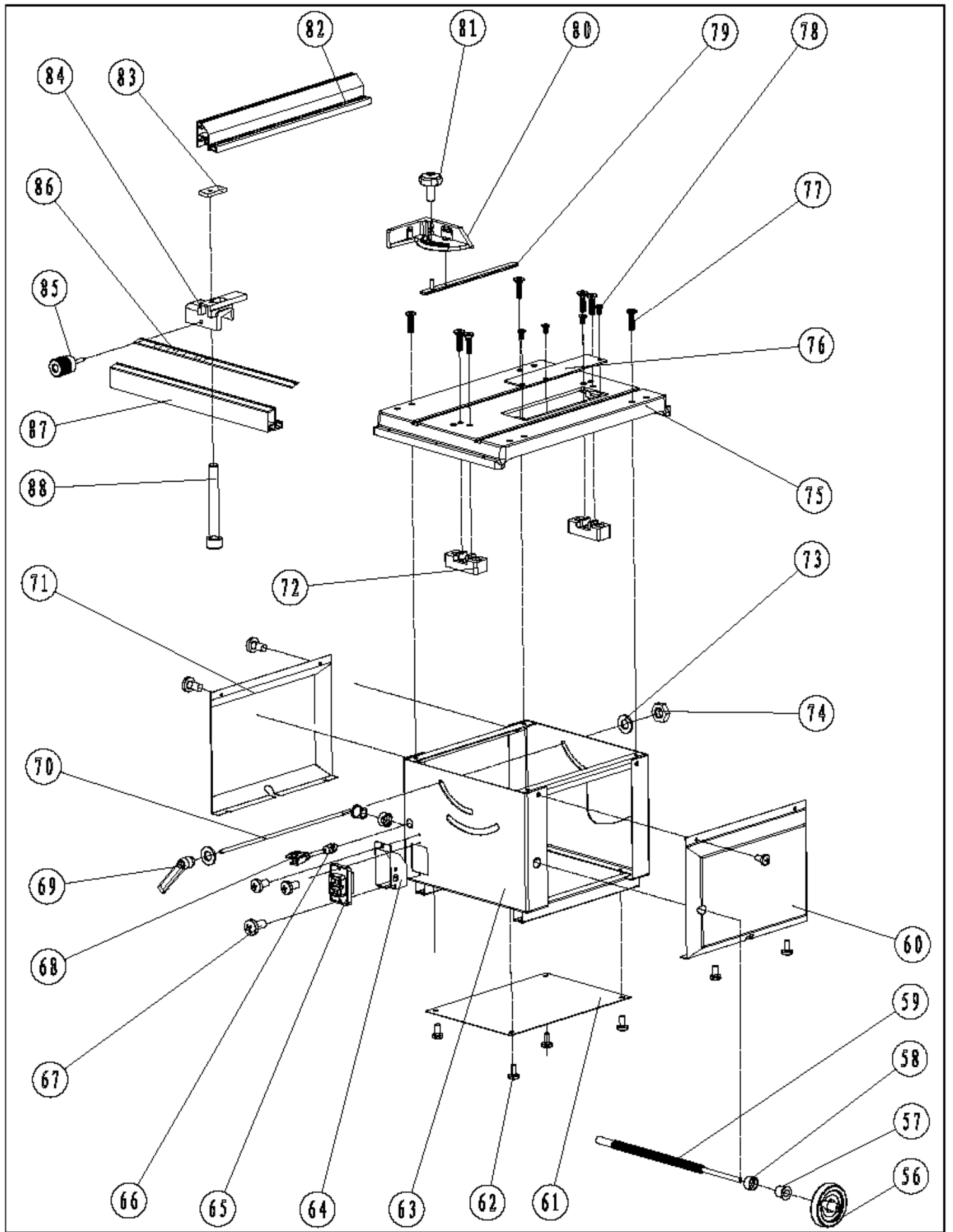

## SLIDING CARRIAGE

Part No	Description	Q'TY	Part No	Description	Q'TY
1	C-shaped ring	1	19	Hex bolt M6X25	1
2	sliding axle	1	20	Angle fence	1
3	Eccentric bush	1	21	"E" ring f16	1
4	Hex thin nut M8	1	22	Press handle	1
5	Set screw M8X25	1	23	Square toes nut	1
6	Eccentric nut	2	24	Angle ruler	1
7	Trolley	4	25	Sliding table	1
8	Washer f6	4	26	Locking nut M10	1
9	T-shaped bolt	1	27	Washer f10	1
10	Set screw M8X10	1	28	Turing plate	1
11	Homocentric nut	2	29	Small handgrip	1
12	Socket countersunk screw	4	30	Washer f6	1
13	Rhombic handgrip	2	31	Locating pole	1
14	Washer f6	3	32	Hex bolt M6X35	1
15	Connecting block	2			
16	Nut M6	1			
17	Washer f6	1			
18	wood block	1			

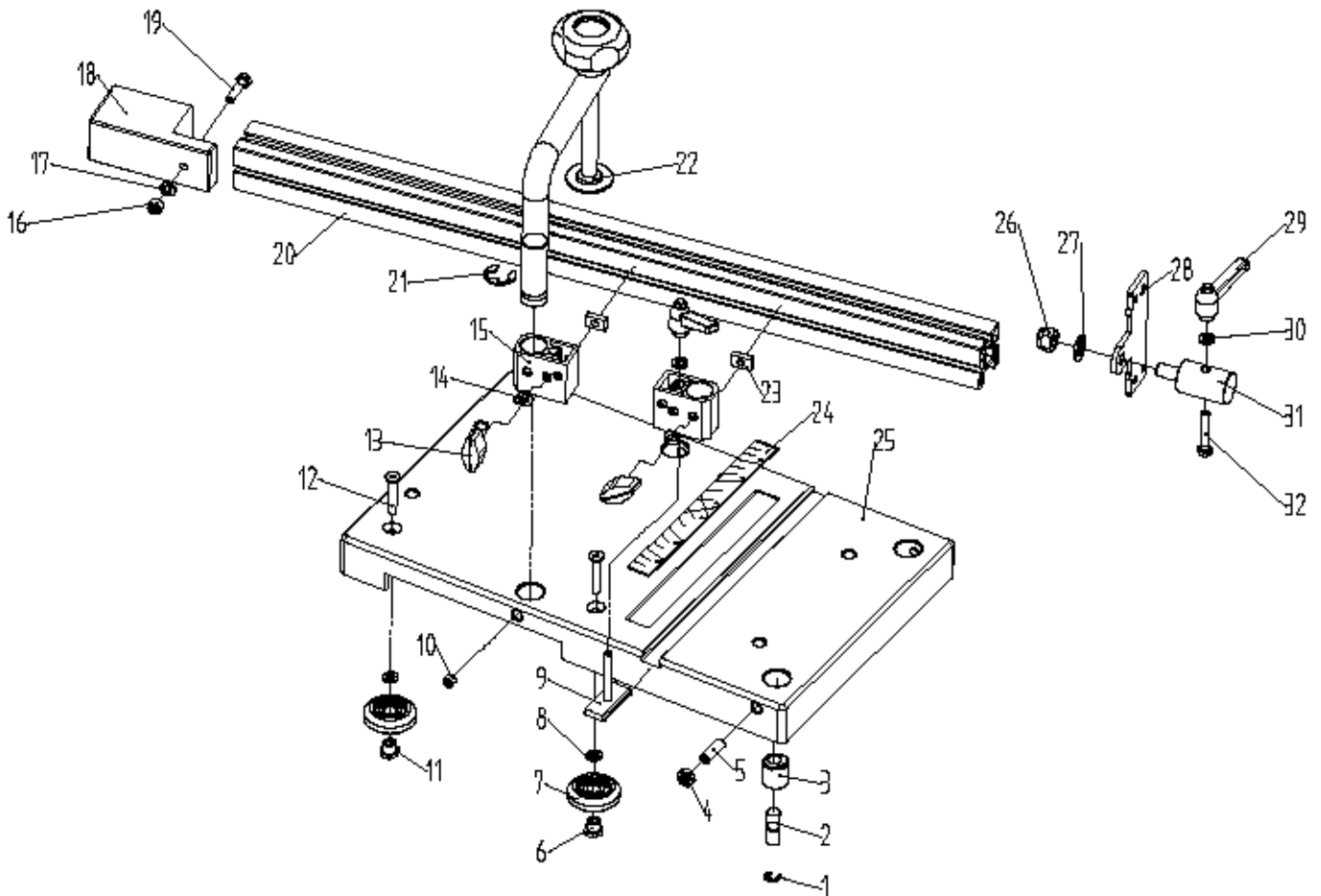

**Extension Table**

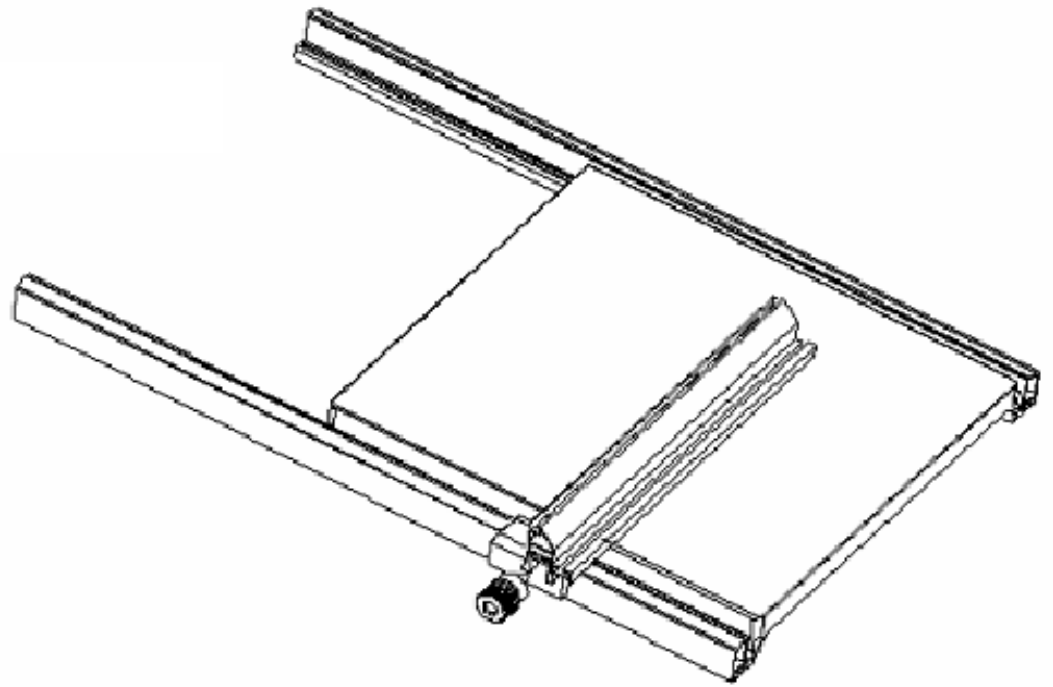

**Floor Stand**

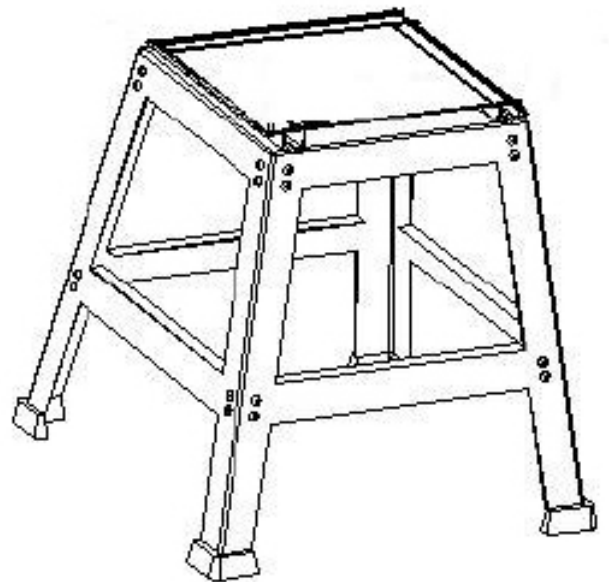

**Sliding Carriage**

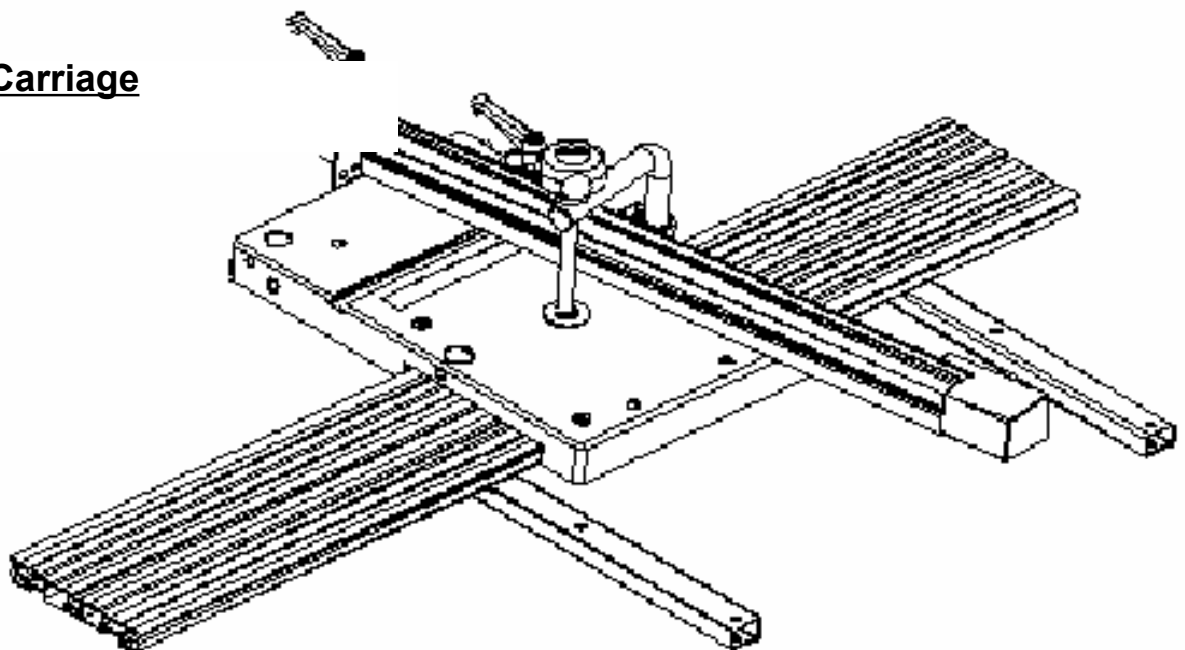



***Woodworking machinery at its best!***

**Charnwood, Cedar Court, Walker Road, Bardon Hill, Leicestershire,  
LE67 1TU**

**Tel. 01530 516926 Fax. 01530 516929**

**email; [sales@charnwood.net](mailto:sales@charnwood.net) website; [www.charnwood.net](http://www.charnwood.net)**