

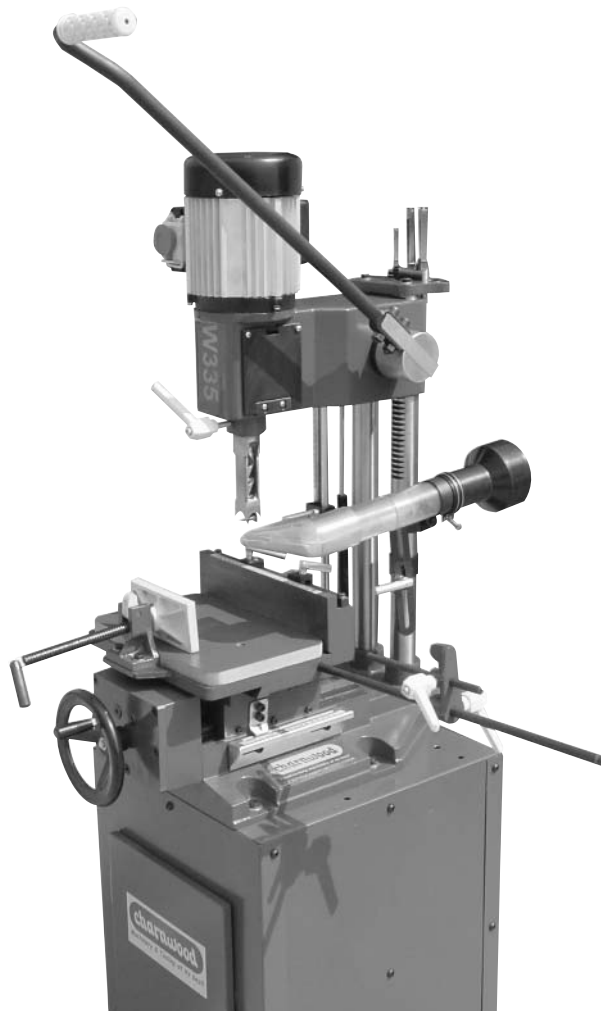

Woodworking machinery at its best!

**1" HOLLOW CHISEL MORTICER
OPERATING INSTRUCTIONS
MODEL: W335**



Charnwood, Cedar Court, Walker Road, Bardon, Leicestershire, LE67 1TU, England

Tel. 01530 516 926 Fax. 01530 516 929

email; sales@charnwood.net

UK customers can view our full range at; www.charnwood.net

WARNING; When using electric tools, basic safety precautions should be followed to reduce risk of fire, electric shock, and personal injury, including the following:

SAFETY INSTRUCTIONS

- 1) KEEP WORK AREA CLEAN - Cluttered areas and benches invite injuries.
- 2) CONSIDER WORK AREA ENVIRONMENT - Do not expose power tools to rain. Do not use power tools in damp or wet locations. Keep work area well lit. Do not use tools in the presence of flammable liquids or gases.
- 3) KEEP CHILDREN AWAY - All visitors should be kept away from work areas.
- 4) STORE IDLE TOOLS - When not in use, tools should be stored in dry, and high or locked-up places out of reach of children.
- 5) DO NOT FORCE THE TOOL - It will do the job better and safer at the rate for which it was intended.
- 6) USE THE RIGHT TOOL - Do not force DIY chisels to do the job of professional chisels. Always use a chisel for its intended use only.
- 7) DRESS PROPERLY - Do not wear loose clothing or jewelry as they can be caught in moving parts. Wear protective hair covering to contain long hair.
- 8) USE SAFETY GLASSES - Also use face or dust mask when operations are dusty. A vacuum cleaner or dust extractor is strongly recommended.
- 9) SECURE THE MACHINE - The machine should be bolted down to the floorstand on a level and stable floor.
- 10) DO NOT OVERREACH - Keep proper footing and balance at all times.
- 11) MAINTAIN CUTTERS WITH CARE - Keep cutters sharp and clean for better and safer performance.
- 12) DISCONNECT FROM MAINS - When not in use and before changing or adjusting chisels.
- 13) CHECK DAMAGED PARTS - Always inspect chisels before use for signs of wear or damage. Do not use cracked or broken chisels.
- 14) STAY ALERT - Use common sense. Do not operate power tools when you are tired or under the influence of drugs, alcohol or medication.

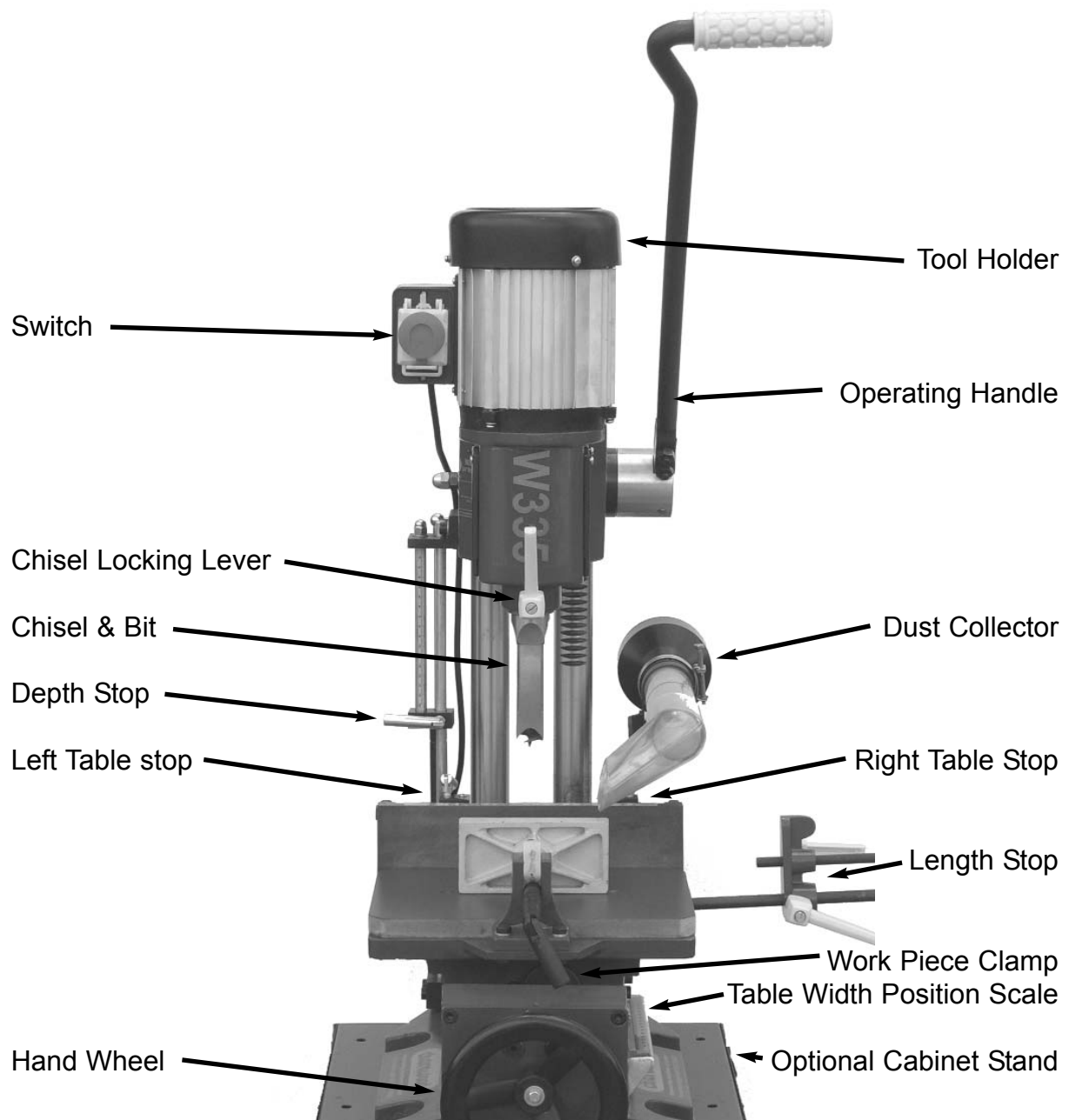

W335 SPECIFICATION

Maximum timber height	160mm
Maximum clamping width	160mm
Chisel capacity Hardwood	1/4" to 5/8"
Chisel capacity Softwood	1/4" to 1"
Accepts chisel collar sizes	3/4", 13/16", 1-1/8", 1-3/16"
Table size	300mm x 160mm
Table travel (left to right)	220mm
Table travel (front to back)	140mm
Working height on Optional floorstand	940mm
Motor (induction)	550w, 240volt
Dimensions (WxDxH)	300mm x 600mm x 1250mm
Weight	75Kg
Rating	Light Trade

UNPACKING

Remove the morticer from the crate, it is bolted to the wooden base, check for damage and ensure all parts are intact. Any damage should be reported immediately to your retailer. Before assembling read the manual thoroughly, familiarising yourself with the correct assembly and maintenance procedures and proper safety precautions.

ASSEMBLY

Lift the morticer onto your workbench or optional cabinet stand and secure with 4 bolts. Warning; The morticer is very heavy, approx 75Kg, take care when lifting to avoid injury.

Fit the operating handle

Locate the two Allen head bolts M10 x 45 and two hex nuts M10.

Fit the main operating handle to the shaft and tighten securely with a 17mm spanner and 8mm allen key.



Fit the handwheel grip

The grip provides a comfortable way of making large adjustments to the morticers table.

Locate the grip and screw it into the treaded insert in the handwheel. Lock with a 10mm spanner.



Fit the length stop

The length stop can be fitted to either the left or right side of the table. Locate the hole on the right hand edge of the table, slide the larger diameter round bar into this hole and secure it with the grub screw located underneath the table using a 4mm hex key.

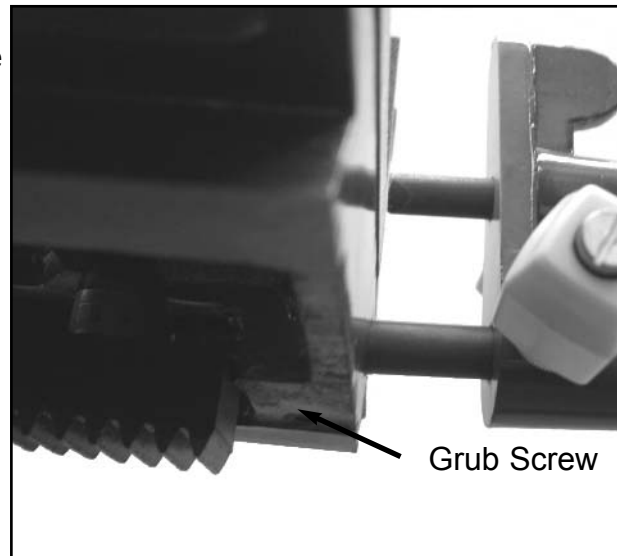

Release the head

There is a packing piece fitted in between the two vertical pillars to prevent the head moving during transport. Carefully remove the packing piece by pulling the operating handle down slightly.

Fit the Dust Collector (Optional)

The dust chute mounting bracket is already fitted to the right hand pillar. Locate the black slotted support collar and lock it into position using the silver handle. Pass the transparent plastic chute through the collar and position the mouth so that the mortice chisel will be central. Secure the transparent chute using a 10mm spanner. Some types of extraction may fit directly onto the round 45mm diameter end of the transparent chute. If you are using a 100mm diameter extraction hose - Fit the black reducing cone onto the tube and tighten the clamp with a 10mm spanner.



Installing / Replacing the Chisel & Bit

Chisels are available with a variety of collar sizes. To allow you to use any brand of chisels we include a set of 4 chisel bushes. The chisel bush fitted in the machine as standard is normally 3/4". The other sizes are 13/16", 1-1/8" & 1-3/16".

Loosen the chisel locking lever and fit the appropriate chisel bush.

Lower the right hand chuck cover by removing 2 pozi head screws and unclipping the top of the hinged cover. Fit the Chisel into the chisel bushing with the open side of the chisel facing to the right and secure with the locking lever. It is important that the open side of the chisel faces to the right to allow waste chips to be drawn out of the hole and ejected (or collected by an extractor) during the cut.

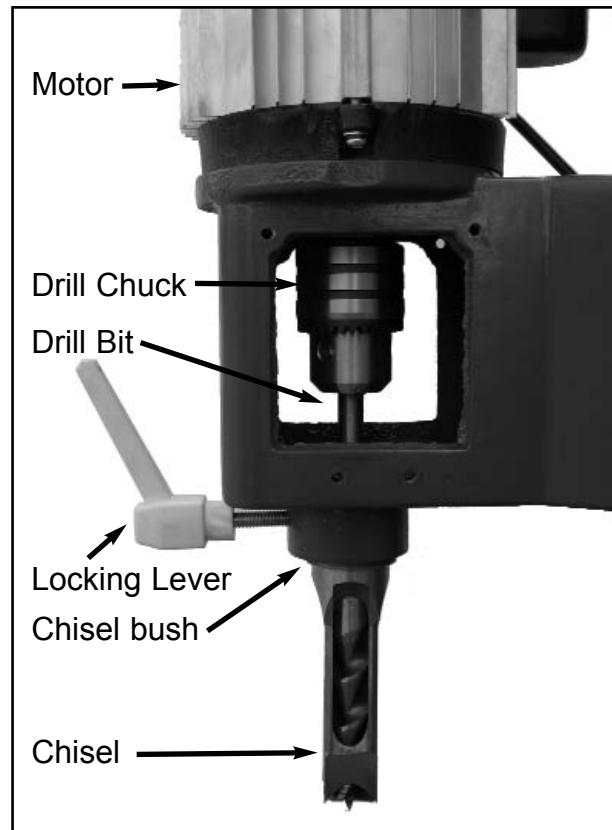

Next set the chisel square to the back fence of the table. Use the operating handle to lower the chisel down to the table. Adjust the table forward until the back fence touches the chisel. Check the back face of the chisel is square to the table fence and adjust as necessary.

Feed the drill bit through the inside of the chisel and into the chuck. Secure using the chuck key supplied.

The drill bit must be set so that the flat cutting edge is lower than the four tips of the chisel. This distance should be between 2mm and 5mm depending on the type of timber being used. If the gap is too small the cut will be more difficult and the waste chips are liable to clog up inside the chisel and stall the motor.

OPERATION

Setting the depth stop

When required a depth stop can be set to control the depth of the mortice cut. When not required we recommend that the stop is set so as to avoid accidentally cutting into the bed of the machine.

The figure shown on the scale is the distance which will be travelled by the chisel before it hits the stop. The actual depth of a cut will vary depending on the height of the workpiece and the length of the chisel being used.

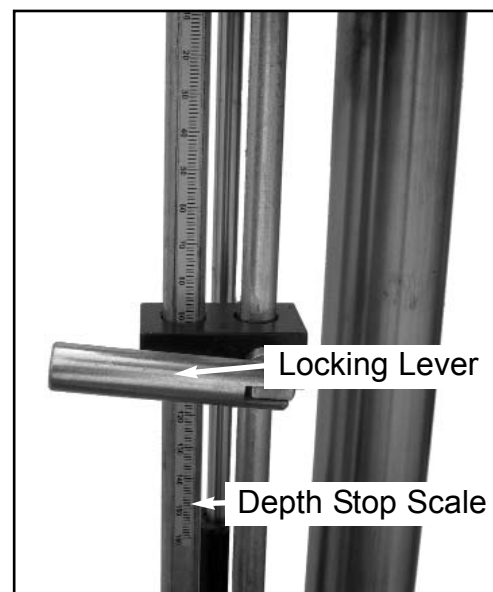

Positioning the table

The table can be moved in two directions;

Front to back table movement is controlled by firstly pulling the handwheel towards you and then rotating it. Turn clockwise to move the table backwards, anti-clockwise to move the table forwards. There is a scale and indicator to show the current position of the table on the right hand side of the machine.

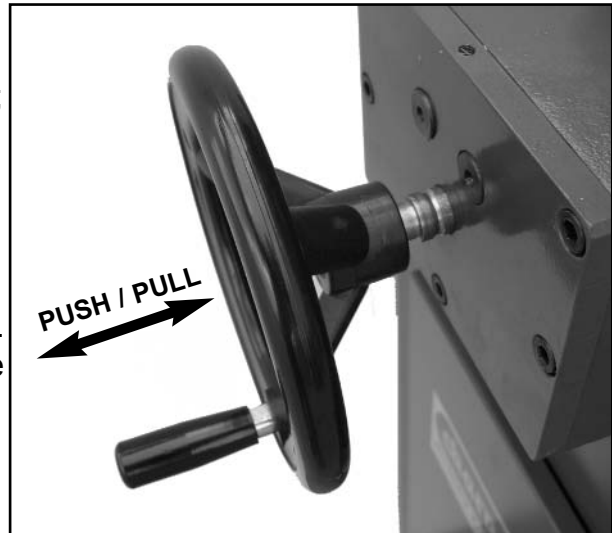

Left and right table movement is controlled by firstly pushing the handwheel away from you and then rotating it. Turn clockwise to move the table to the left, turn anti-clockwise to move the table to the right.

There are two stops fitted to the table to limit the movement for production work.

To set either stop undo the locking lever and slide the stop along the stop bar. There is a scale running along the top of the table and a pointer on each stop. When using the scale to set the width of a mortice cut it is necessary to add the width of the chisel being used to the calculation.

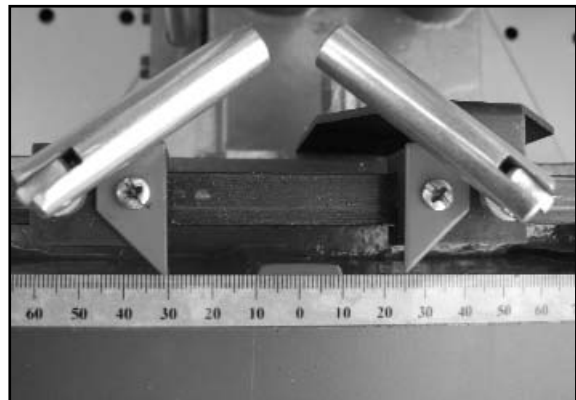

For example if you want to cut a 50mm wide mortice and you are using a 12mm chisel - Set the left hand width stop to 0mm, set the right hand width stop to 38mm.

Clamping the work piece

To speed up operations the work clamp features a quick adjusting system.

With the quick lock segment flipped back, the clamp is free to slide in and out.

To clamp a work piece firstly flip back the quick lock segment and pull the vice jaw out from the back fence. Place the workpiece on the table up against the back fence, flip the quick lock segment forward, push the vice as far as it will go and then withdraw it slightly and turn the locking lever clockwise until the work piece is secure.

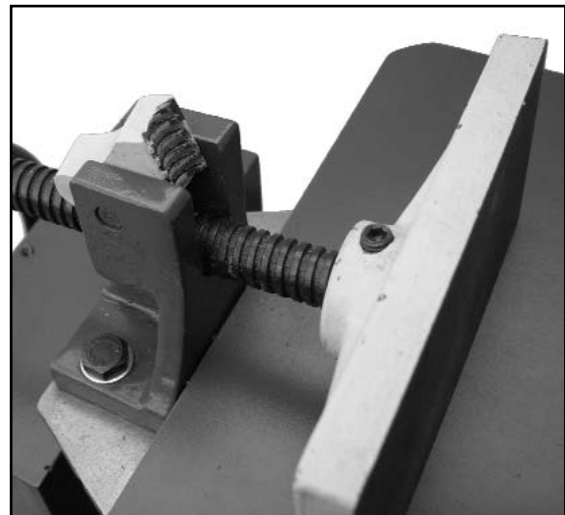

Cutting a Mortice

When cutting a slot mortice it is important to start from the correct end of the work piece. With the open side of the chisel set to the right - start the cut from the right hand edge. As the cut progresses the open side of the chisel will remain open into the hole already cut to aid chip clearance.

If dust extraction is to be used the dust throat should be positioned just above the timber and close to the chisel for best results. The height of the dust throat is adjusted using the locking lever, the angle of the throat can be adjusted by loosening the dust chute collar.

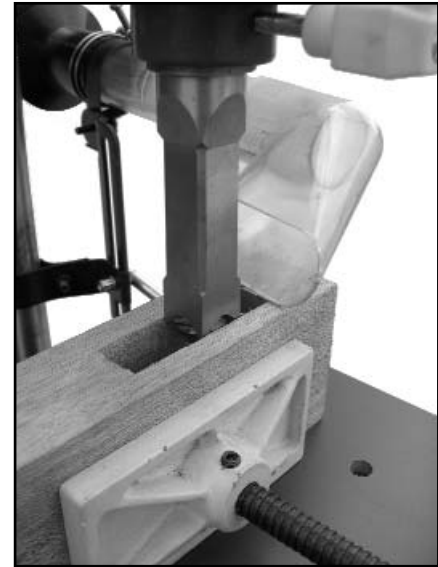

To begin the cut, press the green start button and pull down on the operating handle.

For the initial cut, withdraw the chisel at 20mm depth. Now move the table to the right by the width of the chisel and make a second cut to 20mm. Continue making a series of shallow cuts until the whole outline has been completed. Now go back to the starting position and make a second series of cuts deepening the mortice by a further 20mm. Continue in this fashion until the mortice is to the depth required. If the mortice now needs enlarging in width, use the handwheel to adjust the table forwards or backwards and continue cutting.

Maintenance

There are two adjustable dovetails on the machine. They should be kept clean and lightly oiled. If either of the dovetail slides become too tight or loose they can be adjusted. Along each slide there are a series of Grub screws with a Hex locking nut. These secure the gib strip which sits between the two moving dovetails.

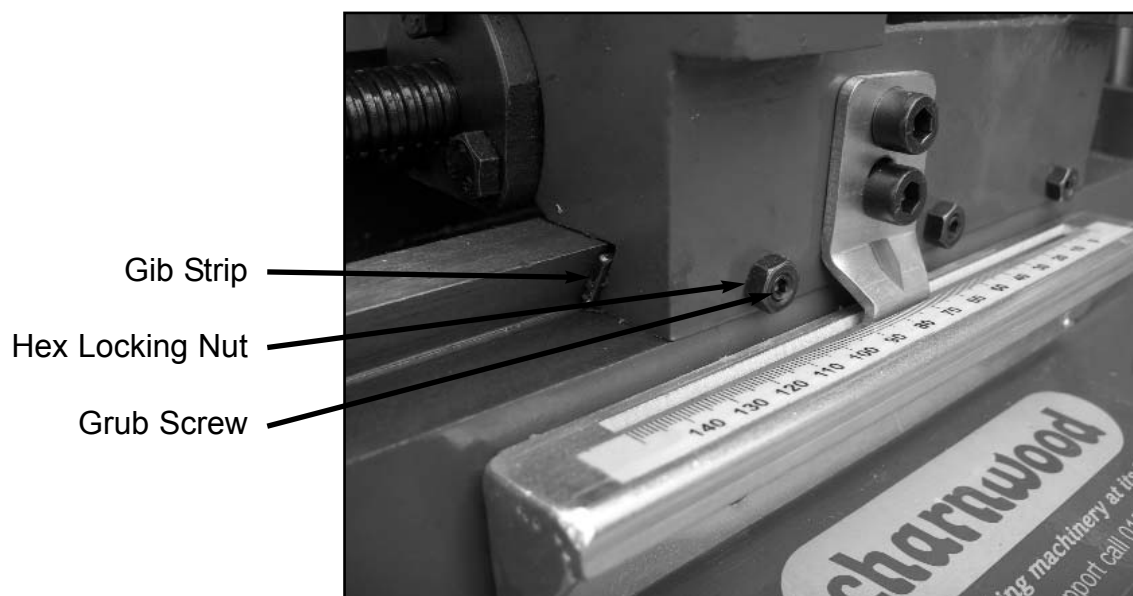

To make an adjustment;

Loosen all of the locking nuts along the dovetail

Back off all of the grub screws

Tighten the two end screws until they make firm contact with the gib strip

Lock the two end screws with the Hex nut

Try moving the dovetail slide, adjust it tighter or looser as required then tighten and lock the third set screw.

Sharpening the Chisel & Bit

The chisel & bit should be kept sharp for best performance. Blunt edges will give inaccurate mortices and can cause overheating and breakage to the chisel.

The drill bit can be sharpened using a small smooth file following the original shape of the bit. File the inside edge of the spur, the sides of the brad point and the cutting edge inwards toward the flute of the bit. Do not file the outside edge of the spur as this will affect the diameter of the bit.

Sharpening of the chisel is best left to a specialist sharpening centre although tools for sharpening mortice chisels are commercially available.

Environmental Information

Please dispose of packaging for the product in a responsible manner. It is suitable for recycling. Help to protect the environment, take the packaging to the local amenity tip and place into the appropriate recycling bin.

Do not dispose of electric tools together with household waste material.

In observance of European Directive 2002/96/EC on waste electrical and electronic equipment (EEE) and its implementation in accordance with national law, electric tools that have reached the end of their life must be collected separately and returned to an environmentally compatible recycling facility.

Your local refuse amenity will have a separate collection area for EEE goods.

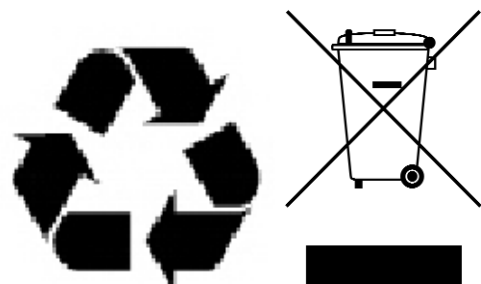

No	Description	No	Description
1	Base	48	Sliding key
2	Block, depth stop	49	Gear 3
3	Set screw M8x16	50	Collar
4	Washer 8mm	51	Sliding guide 3x15x200
5	Hex head screw M8x40	52	Set screw M6x25
6	Depth stop rod	53	Hex nut M6
7	Collar stop	54	Special nut
8	Ratchet lever	55	Table carrier
9	Bracket, depth stop	56	Sliding guide 3x15x64
10	Cylinder, gas	57	Thread stud
11	Hex head screw M8x40	58	Stud
12	Pillar	59	Flat key 6x6x12
13	Pillar w/rack	60	Collar stop
14	Hex nut M10	61	Gear 2
15	Washer 10mm	62	Set screw M8x12
16	Head	63	handle wheel
17	Stop plate	64	Cover, gear box
18	Hex head screw M8x20	65	Ball 5mm
19	Set screw M10x12	66	Coil spring
20	Gear	67	Set screw M6x12
21	Power cord	68	Gear box
22	Main switch	69	Bush
23	Chuck	70	Hex nut M12
24	Pan head screw M5x 10	71	Circle ring
25	Pan head screw M3x 10	72	Gear 1
26	Lower cover, head	73	Flat key 4x4x 10
27	Cover, head	74	Gear shaft
28	Allen screw M8x20	75	Quick lock handle
29	Chisel & bit	76	Roll pin 5x16
30	Elevation disc	77	Quick lock stud
31	Elevation shaft	78	Vise jaw
32	Flat key 6x6x20	79	Set screw M5x16
33	Elevation knot	80	Rack
34	Lock pin	81	Table
35	Hex nut M10	82	Base, working stop
36	Bush, handle	83	Rod, working stop
37	Handle	84	Rod, working stop
38	Allen screw M10x45	85	Allen screw M8x25
39	Rock block	86	Square bar, width stop
40	Roll pin 6x22	87	Stop, width
41	Allen screw M8x16	88	Pointer, width stop
42	Circle ring	89	Pan head screw M6x8
43	Roll pin 8x70	90	Scale, width
44	Pin	91	Allen screw M8x30
45	Coil spring	92	Lock jaw
46	Sunk head screw M4x15	93	Bracket, quick lock
47	Collar	94	Roll pin 8x35

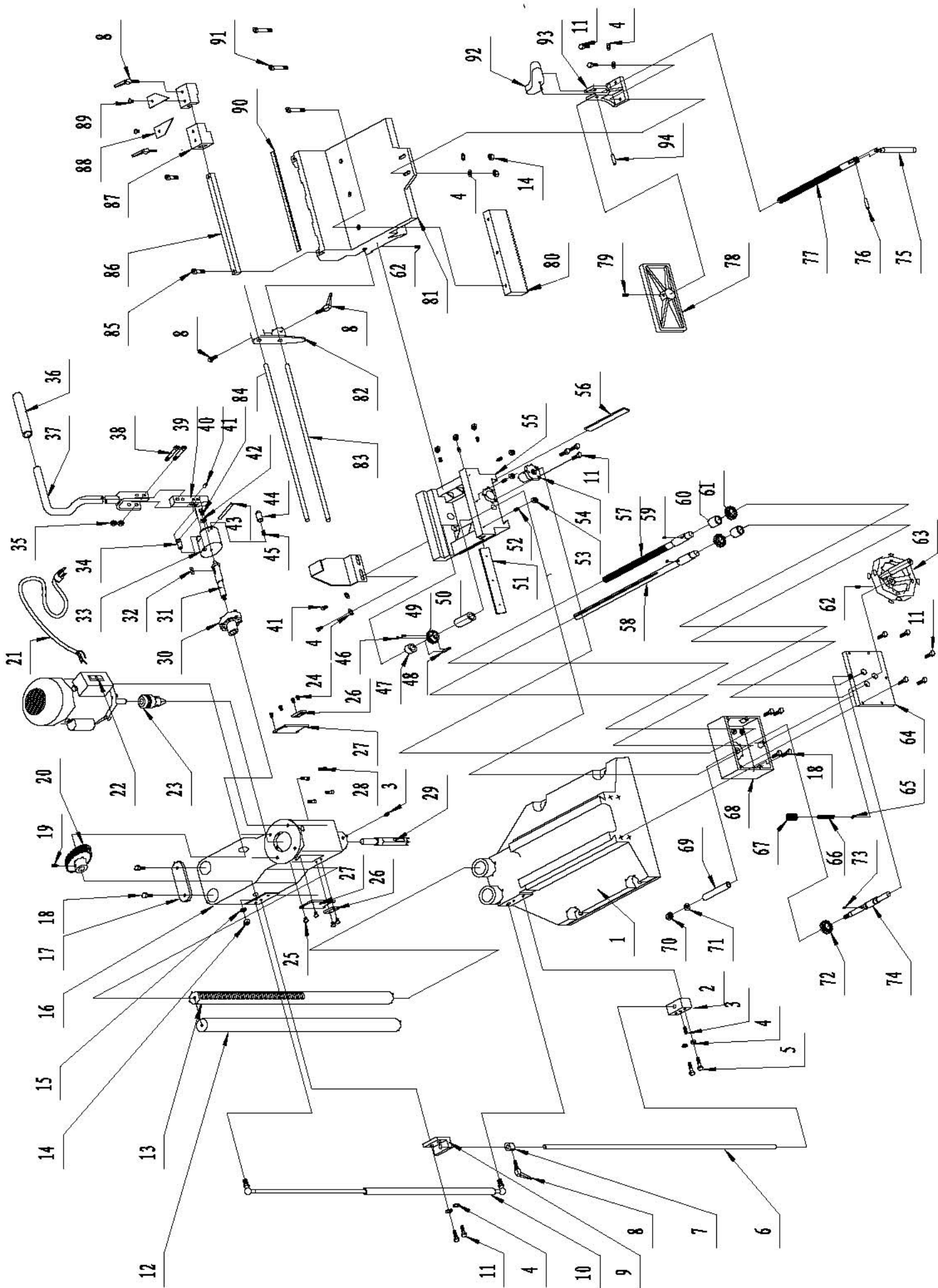



Woodworking machinery at its best!

Charnwood, Cedar Court, Walker Road, Bardon, Leicestershire, LE67 1TU, England
Tel. 01530 516 926 Fax. 01530 516 929
email; sales@charnwood.net
View our full range at; www.charnwood.net