



Woodworking machinery at its best!

1" INDUSTRIAL MORTICER OPERATING INSTRUCTIONS MODEL: W350



Charnwood, Cedar Court, Walker Road, Bardon, Leicestershire, LE67 1TU, England

Tel. 01530 516 926 Fax. 01530 516 929

email; sales@charnwood.net

UK customers can view our full range at; www.charnwood.net

WARNING; When using electric tools, basic safety precautions should be followed to reduce risk of fire, electric shock, and personal injury, including the following:

SAFETY INSTRUCTIONS

- 1) KEEP WORK AREA CLEAN - Cluttered areas and benches invite injuries.
- 2) CONSIDER WORK AREA ENVIRONMENT - Do not expose power tools to rain. Do not use power tools in damp or wet locations. Keep work area well lit. Do not use tools in the presence of flammable liquids or gases.
- 3) KEEP CHILDREN AWAY - All visitors should be kept away from work areas.
- 4) STORE IDLE TOOLS - When not in use, tools should be stored in dry, and high or locked-up places out of reach of children.
- 5) DO NOT FORCE THE TOOL - It will do the job better and safer at the rate for which it was intended.
- 6) USE THE RIGHT TOOL - Do not force DIY chisels to do the job of professional chisels. Always use a chisel for its intended use only.
- 7) DRESS PROPERLY - Do not wear loose clothing or jewelry as they can be caught in moving parts. Wear protective hair covering to contain long hair.
- 8) USE SAFETY GLASSES - Also use face or dust mask when operations are dusty. A vacuum cleaner or dust extractor is strongly recommended.
- 9) SECURE THE MACHINE - The machine should be bolted down to the floorstand on a level and stable floor.
- 10) DO NOT OVERREACH - Keep proper footing and balance at all times.
- 11) MAINTAIN CUTTERS WITH CARE - Keep cutters sharp and clean for better and safer performance.
- 12) DISCONNECT FROM MAINS - When not in use and before changing or adjusting chisels.
- 13) CHECK DAMAGED PARTS - Always inspect chisels before use for signs of wear or damage. Do not use cracked or broken chisels.
- 14) STAY ALERT - Use common sense. Do not operate power tools when you are tired or under the influence of drugs, alcohol or medication.

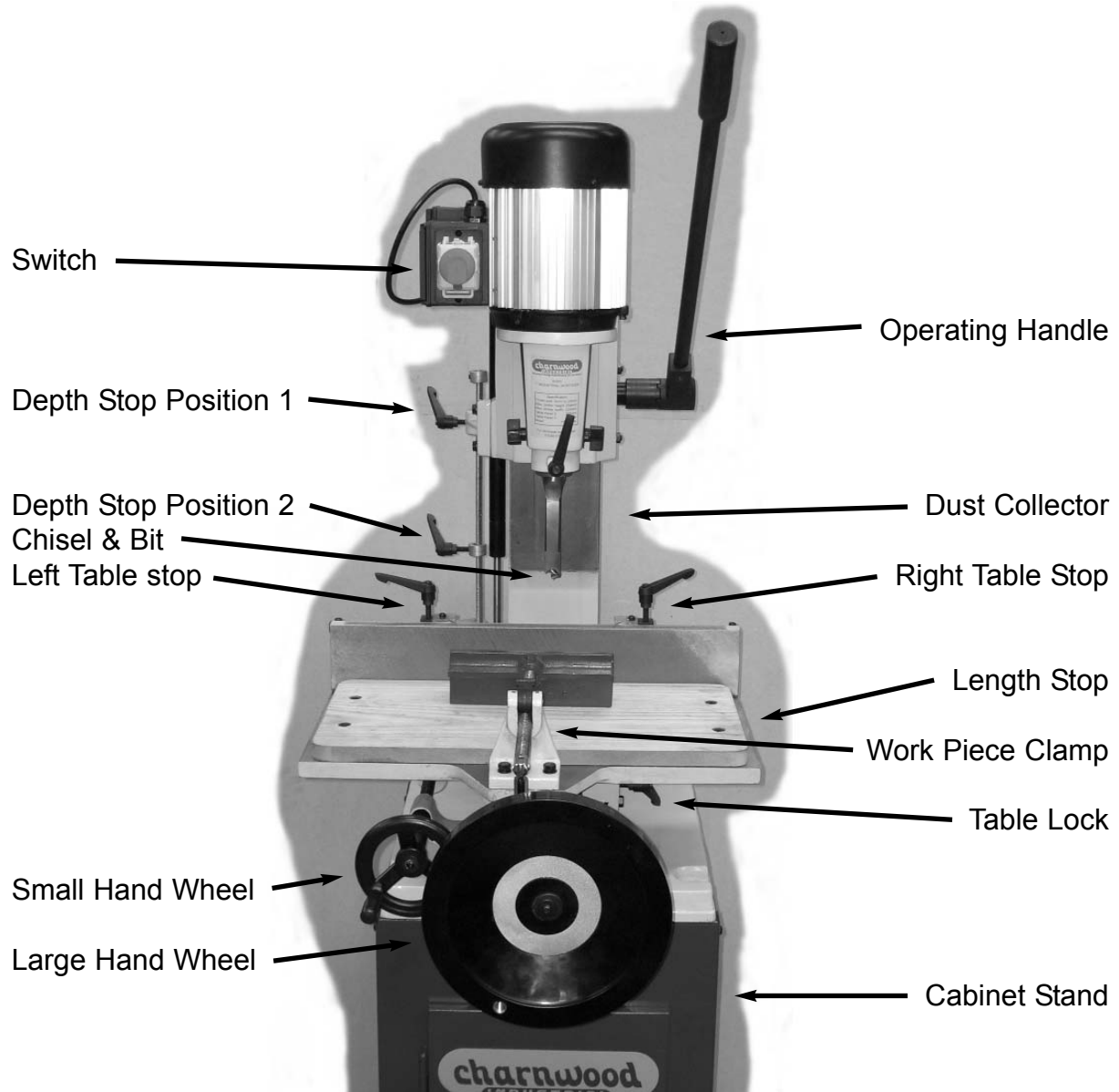

W350 SPECIFICATION

Maximum timber height	250mm
Maximum clamping width	222mm
Chisel capacity	1/4" to 1"
Accepts chisel collar sizes	3/4", 13/16", 1.1/8", 1.3/16"
Table size	520mm x 220mm
Table travel (left to right)	395mm
Table travel (front to back)	151mm
Working height on floorstand	990mm
Motor (induction)	1500W, 240volt
Dimensions on floorstand (WxDxH)	520mm x 800mm x 2000mm
Weight	121Kg
Rating	Industrial

UNPACKING

Remove the morticer from the crate, check for damage and ensure all parts are intact. Any damage should be reported immediately to your retailer. Before assembling read the manual thoroughly, familiarising yourself with the correct assembly and maintenance procedures and proper safety precautions.

ASSEMBLY

Assemble the cabinet stand packed in a separate carton using the instructions inside.

Lift the morticer onto the stand and secure with the 4 bolts provided. Warning; The morticer is very heavy, approx 100Kg, take care when lifting to avoid injury.

Fit the operating handle -
Undo the locking bolt, part 78, using a 10mm hex key, and remove the spring. Fit the operating handle over the shaft and engage into the castle slots. Refit the spring and then the locking bolt.



Fit the small handwheel - Slide the small handwheel onto the left hand shaft, part 6, and secure it by tightening the 2 cap head bolts with a 4mm hex key.

Fit the large handwheel - Slide the large handwheel onto the central shaft, part 20, and secure it by tightening the 2 cap head bolts with a 4mm hex key.

Fit the length stop -
Locate the hole on the right hand edge of the table, part 27, slide the larger diameter round bar into this hole and secure it with the grub screw located underneath the table using a 3mm hex key.

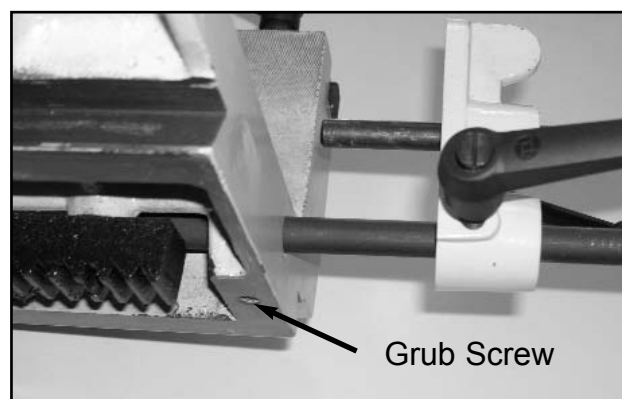

Unlock the head - Undo the ratchet lever located at the bottom end of the depth stop rod, part 75, and remove the collar stop. Use the operating handle to raise the head of the machine until the depth stop rod is clear of the hole in the depthstop base. Refit the collar stop to the stop rod and lock into place.

Dust Collector -

The perspex dust chute is already fitted to the side of the machine. Attach the 100mm dust outlet, Part 99, using the collar clamp, part 97.



Installing / Replacing the Chisel & Bit

Chisels are available with a range of collar sizes. To allow you to use any brand of chisels we include a set of 4 chisel bushes, part 111. The chisel bush fitted in the machine as standard is 3/4". The other sizes are 13/16", 1.1/8" & 1.3/16".

Loosen the chisel locking knob and fit the appropriate chisel bush.
Lower the right hand chuck cover, part 47, by removing 2 cap head bolts and loosening the locking knob, part 58.
Fit the Chisel into the chisel bushing with the open side of the chisel facing to the right and secure with the locking knob. It is important that the open side of the chisel faces either to the right to allow waste chips to be drawn out of the hole and ejected (or collected by an extractor) during the cut.
Next set the chisel square to the back fence of the table. Use the operating handle to lower the chisel down to the table. Adjust the table forward until the back fence touches the chisel. Check the back face of the chisel is square to the table fence and adjust as necessary.

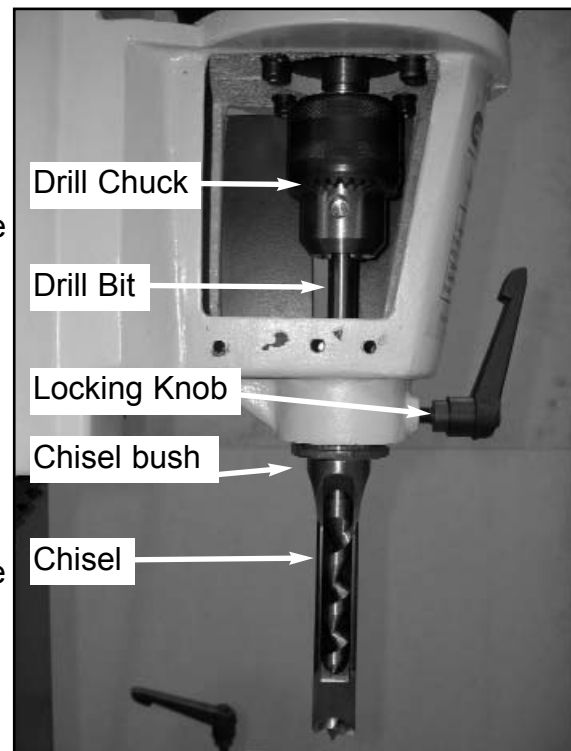

Feed the drill bit through the inside of the chisel and into the chuck, part 43. Secure using the chuck key.

The drill bit must be set so that the flat cutting edge is lower than the four tips of the chisel. This distance should be between 2mm and 5mm depending on the type of timber being used. If the gap is too small the cut will be more difficult and the waste chips are liable to clog up inside the chisel and stall the motor.

OPERATION

Setting the depth stop

When required a depth stop can be set to control the depth of the mortice cut.

When not required we recommend that the stop is set so as to avoid accidentally cutting into the bed of the machine. It is possible to keep two depth positions set at the same time.

Position 1 - Rotate the haunching plate, part 73, so that it covers the hole in the depth stop base, part 72. Undo the ratchet lever on the depth stop rod support, part 79, to release the rod which can now be positioned to set the depth of cut. As the head is lowered the bottom of the rod will stop against the haunching plate.

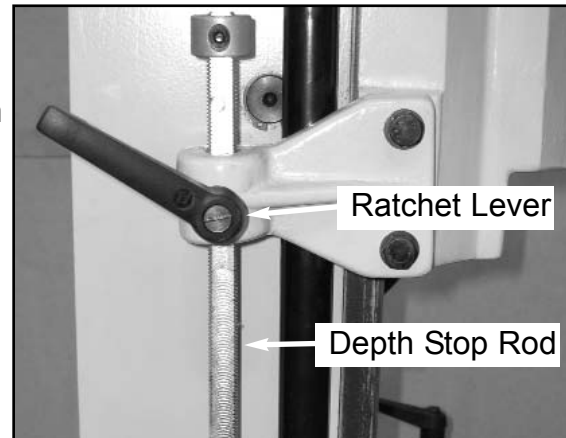

Position 2 - Rotate the haunching plate, part 73, so that the hole in the depth stop base is visible. Undo the ratchet lever on the collar stop, part 74, and position it as required along the stop rod. When the head is lowered the rod will pass through this hole until stopped by the collar.

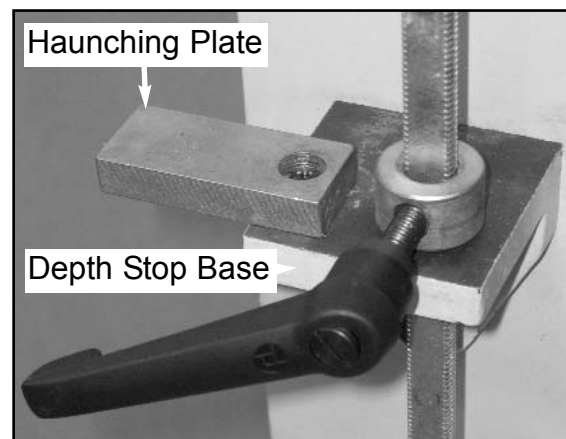

Position the table

The table can be moved in two directions;

Front to back table movement is controlled by the smaller hand wheel, part 10, on the left hand side of the machine. There is a locking lever, part 18, located underneath the table on the right hand side. Unlock the lever and rotate the hand wheel to adjust the table forwards or backwards as required. It is best practice to lock the table whilst making a cut.

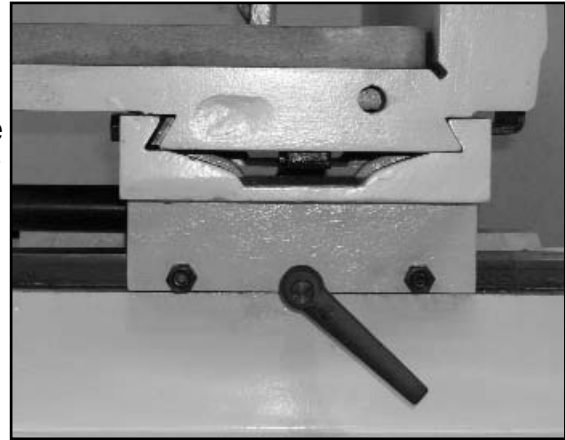

Left and right table movement is controlled using the larger central hand wheel, part 22. there are two stops, part 28, fitted to the table to limit the movement for production work.

To set either stop undo the ratchet lever and slide the stop block along width stop bar, part 29. There is a scale running along the top of the table and a pointer on each stop. When using the scale to set the width of a mortice cut it is necessary to add the width of the chisel being used to the calculation.

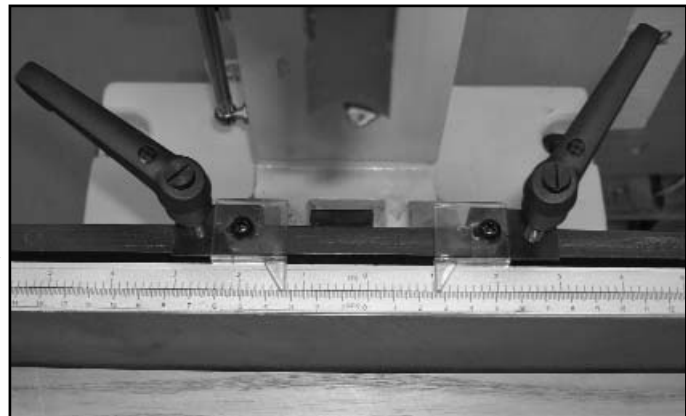

For example if you want to cut a 3" wide mortice and you are using a 3/4" chisel - Set the left hand width stop to 0", set the right hand width stop to 2.1/4"

Clamping the work piece

To speed up operations the work clamp features a quick adjusting system. With the quick lock segment, part 102, flipped back the clamp is free to slide in and out. To clamp a work piece firstly flip back the quick lock segment and pull the vice jaw out from the back fence. Place the workpiece on the table up against the back fence, flip the quick lock segment forward as far as it will go and then withdraw it slightly, turn the locking lever, part 61, clockwise until the work piece is secure.

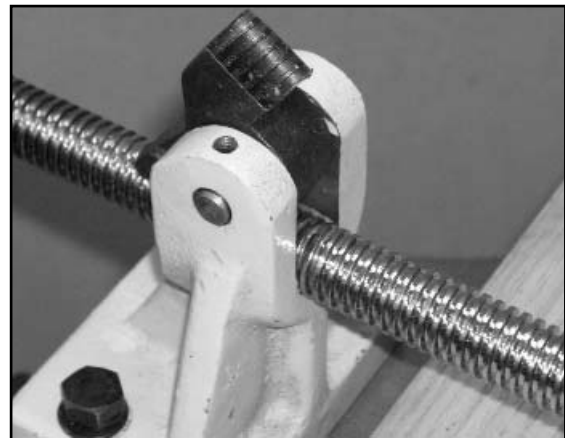

Cutting a Mortice

When cutting a slot mortice it is important to start from the correct end of the work piece. With the open side of the chisel set to the right - start the cut from the right hand edge. As the cut progresses the open side of the chisel will remain open into the hole already cut to aid chip clearance. If dust extraction is to be used the dust throat, part 94, should be positioned just above the timber and close to the chisel for best results. The height of the dust throat is adjusted using the ratchet lever, the angle of the throat can be adjusted by loosening the dust outlet clamp, part 95.



To begin the cut press the green start button and pull down on the operating handle, part 55. For the initial cut, withdraw the chisel at 1" depth. Now move the table to the right by up to the width of the chisel and make a second cut to the same depth as the first. Continue making a series of shallow cuts until the whole outline has been completed. Now go back to the starting position and make a second series of cuts deepening the mortice by a further 1". Continue in this fashion until the mortice is to the depth required.

If the mortice now needs enlarging in length, unlock the table, wind the left hand wheel until the table is in the required position, lock the table and continue cutting.

Maintenance

There are three adjustable dovetails on the machine. They should be kept clean and lightly oiled. If any of the dovetail slides become too tight or loose they can be adjusted. Along each slide there are a series of Grub screws with a Hex locking nut. These secure the gib strip which sits between the two moving dovetails.

Grub Screw
Hex Locking Nut
Gib Strip



To make an adjustment;

Loosen all of the locking nuts along the dovetail

Back off all of the grub screws

Tighten the two end screws until they make firm contact with the gib strip

Lock the two end screws with the Hex nut

Try moving the dovetail slide, adjust it tighter or looser as required then tighten and lock the third set screw.

Sharpening the Chisel & Bit

The chisel & bit should be kept sharp for best performance. Blunt edges will give inaccurate mortices and can cause overheating and breakage to the chisel.

The drill bit can be sharpened using a small smooth file following the original shape of the bit. File the inside edge of the spur, the sides of the brad point and the cutting edge inwards toward the flute of the bit. Do not file the outside edge of the spur as this will affect the diameter of the bit.

Sharpening of the chisel is best left to a specialist sharpening centre although tools for sharpening mortice chisels are commercially available.